

---

**U.S. ARMY MEDICAL DEPARTMENT CENTER AND SCHOOL  
FORT SAM HOUSTON, TEXAS 78234-6100**

---

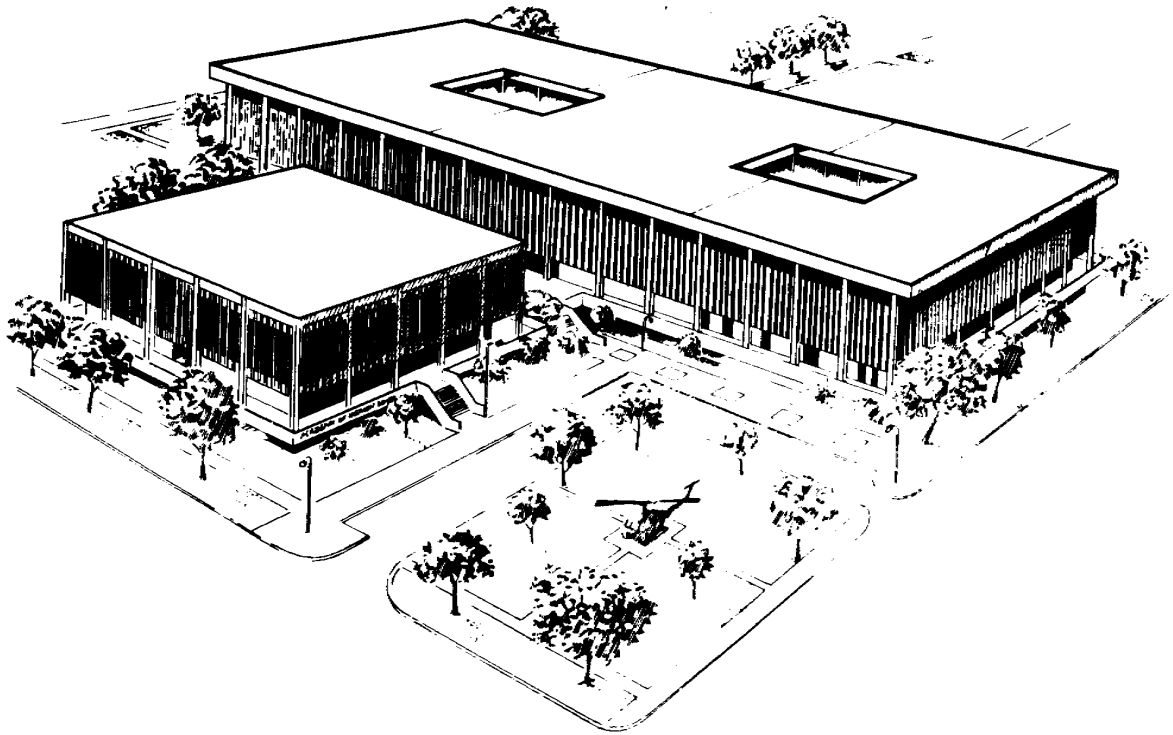

# **FOOD CONTAINERS**

**SUBCOURSE MD0708**

**EDITION 100**

## **DEVELOPMENT**

This subcourse is approved for resident and correspondence course instruction. It reflects the current thought of the Academy of Health Sciences and conforms to printed Department of the Army doctrine as closely as currently possible. Development and progress render such doctrine continuously subject to change.

When used in this publication, words such as "he," "him," "his," and "men" are intended to include both the masculine and feminine genders, unless specifically stated otherwise or when obvious in context.

Proprietary names, that is, brand names or trademarks, have been used in this text solely to make it a more effective learning aid. The use of any name, proprietary or otherwise, should not be interpreted as endorsement, deprecation, or criticism of a product. Nor should such use be considered to interpret the validity of the proprietary rights in a name, whether it be registered or not.

The subject matter experts responsible for the revision of this edition were from the Department of Veterinary Science: DSN 471-6357 or area code 210-221-6357; Commander, U.S. Army Medical Department Center and School, ATTN: MCCS-HV, Fort Sam Houston, Texas 78234-6100.

## **ADMINISTRATION**

Students who desire credit hours for this correspondence subcourse must meet eligibility requirements and must enroll through the Nonresident Instruction Branch of the U.S. Army Medical Department Center and School (AMEDDC&S).

Application for enrollment should be made at the Internet website: <http://www.atrrs.army.mil>. You can access the course catalog in the upper right corner. Enter School Code 555 for medical correspondence courses. Copy down the course number and title. To apply for enrollment, return to the main ATRRS screen and scroll down the right side for ATRRS Channels. Click on SELF DEVELOPMENT to open the application and then follow the on screen instructions.

In general, eligible personnel include enlisted personnel of all components of the U.S. Army who hold an AMEDD MOS or MOS 18D. Officer personnel, members of other branches of the Armed Forces, and civilian employees will be considered eligible based upon their AOC, NEC, AFSC or Job Series which will verify job relevance. Applicants who wish to be considered for a waiver should submit justification to the Nonresident Instruction Branch at e-mail address: [accp@amedd.army.mil](mailto:accp@amedd.army.mil).

For comments or questions regarding enrollment, student records, or shipments, contact the Nonresident Instruction Branch at DSN 471-5877, commercial (210) 221-5877, toll-free 1-800-344-2380; fax: 210-221-4012 or DSN 471-4012, e-mail [accp@amedd.army.mil](mailto:accp@amedd.army.mil), or write to:

NONRESIDENT INSTRUCTION BRANCH  
AMEDDC&S  
ATTN: MCCS-HSN  
2105 11TH STREET SUITE 4191  
FORT SAM HOUSTON TX 78234-5064

## TABLE OF CONTENTS

<u>Lesson</u>	<u>Paragraphs</u>	<u>Page</u>
INTRODUCTION .....		iv
1 INTRODUCTION TO FOOD CONTAINERS.....	1-1--1-19	1-2
Exercises .....		1-22
2 INSPECTION OF FOOD CONTAINERS		
Section I. Incubation and Measuring Vacuum.....	2-1--2-5	2-3
Section II. Container Defects .....	2-6--2-18	2-8
Exercises .....		2-23

## LIST OF ILLUSTRATIONS

<u>Figure</u>		<u>Page</u>
1-1	Can fabrication showing tin plate thickness and seam formation of a sanitary can.....	1-3
1-2	Can fabrication.....	1-5
1-3	Can end .....	1-6
1-4	Can styles .....	1-8
1-5	Common trade names for round cans.....	1-11
1-6	Measuring the size of a round can .....	1-12
1-7	Measuring the size of a square or rectangular can .....	1-13
1-8	Measuring the size of an oval (pear-shaped) can .....	1-14
1-9	Parts of a can.....	1-17
1-10	Parts of a glass container .....	1-18
1-11	Parts of a tray pack can .....	1-19
1-12	Parts of a retort pouch .....	1-21
2-1	Vacuum gauge, end-puncture type.....	2-5
2-2	Measuring vacuum of a tray pack can .....	2-5
2-3	Can end, showing where to place the vacuum gauge .....	2-7
2-4	End seam dent.....	2-10
2-5	Body dent not involving the end seam .....	2-11
2-6	Body dent involving the end seam .....	2-12
2-7	Buckling, a buckled can .....	2-13
2-8	Cable cut.....	2-15
2-9	Enamel fractures, scarred and flaked enamel.....	2-17
2-10	Breakage characteristics of glass jars.....	2-18
2-11	Surface markings on broken glass containers .....	2-19

## LIST OF TASKS SUPPORTED

<u>Task Number</u>		<u>Lesson</u>
081-892-1020	INSPECT PERISHABLE SUBSISTENCE FOR OBVIOUS DEFECTS	1 & 2
081-892-1023	INSPECT SEMIPERISHABLE SUBSISTENCE FOR OBVIOUS DEFECTS	1 & 2
081-892-1042	INSPECT RETAIL/BOXED BEEF FOR OBVIOUS DEFECTS	1 & 2
081-892-1043	INSPECT RETAIL/BOXED PORK FOR OBVIOUS DEFECTS	1 & 2
081-892-1044	INSPECT WATERFOOD FOR OBVIOUS DEFECTS	1 & 2
081-892-1045	INSPECT POULTRY ITEMS FOR OBVIOUS DEFECTS	1 & 2
081-892-1046	INSPECT PRODUCE FOR OBVIOUS DEFECTS	1 & 2
081-892-1047	INSPECT DAIRY PRODUCTS FOR OBVIOUS DEFECTS	1 & 2
081-892-1048	INSPECT SHELL EGGS FOR OBVIOUS DEFECTS	1 & 2
081-892-1050	INSPECT FROZEN FOODS FOR OBVIOUS DEFECTS	1 & 2
081-892-1051	INSPECT CEREAL OR BAKERY ITEMS FOR OBVIOUS DEFECTS	1 & 2
081-892-1052	INSPECT CANNED FOODS FOR OBVIOUS DEFECTS	1 & 2

**CORRESPONDENCE COURSE OF  
THE U.S. ARMY MEDICAL DEPARTMENT CENTER AND SCHOOL**

**SUBCOURSE MD0708**

**FOOD CONTAINERS**

**INTRODUCTION**

Food containers must be inspected to ensure that the canning process, or thermostabilization, has been properly performed so that there is a highly acceptable food product. This will include checking for container defects associated with the actual manufacturing as well as those caused by constant handling or mishandling. The veterinary food inspection specialist must know how to identify and classify defective containers and to see that they are removed from the food supply system.

***Subcourse Components:***

This subcourse consists of two lessons and an examination. The lessons are:

Lesson 1, Introduction to Food Containers.

Lesson 2, Inspection of Food Containers.

***Credit Awarded:***

Upon successful completion of this subcourse, you will be awarded 5 credit hours.

***Materials Furnished:***

Materials provided include this booklet, an examination answer sheet, and an envelope. Answer sheets are not provided for individual lessons in this subcourse because you are to grade your own lessons. Exercises and solutions for all lessons are contained in this booklet. *You must furnish a #2 pencil.*

***Procedures for Subcourse Completion:***

You are encouraged to complete the subcourse lesson by lesson. When you have completed all of the lessons to your satisfaction, fill out the examination answer sheet and mail it to the U.S. Army Medical Department Center and School along with the Student Comment Sheet in the envelope provided. *Be sure that your name, rank, social security number, and return address are on all correspondence sent to the U.S. Army Medical Department Center and School.* You will be notified by return mail of the examination results. Your grade on the exam will be your rating for the subcourse.

***Study Suggestions:***

Here are suggestions that may be helpful to you in completing this subcourse:

--Read and study each lesson carefully.

--Complete the subcourse lesson by lesson. After completing each lesson, work the exercises at the end of the lesson, marking your answers in this booklet.

--After completing each set of lesson exercises, compare your answers with those on the solution sheet, which follows the exercises. If you have answered an exercise incorrectly, check the reference cited after the answer on the solution sheet to determine why your response was not the correct one.

--As you successfully complete each lesson, go on to the next. When you have completed all of the lessons, complete the examination. Mark your answers in this booklet; then transfer your responses to the examination answer sheet using a #2 pencil.

***Student Comment Sheet:***

Be sure to provide us with your suggestions and criticisms by filling out the Student Comment Sheet (found at the back of this booklet) and returning it to us with your examination answer sheet. Please review this comment sheet before studying this subcourse. In this way, you will help us to improve the quality of this subcourse.

## **LESSON ASSIGNMENT**

### **LESSON 1**

Introduction to Food Containers.

### **LESSON ASSIGNMENT**

Paragraphs 1-1 through 1-19.

### **LESSON OBJECTIVES**

After completing this lesson, you should be able to:

- 1-1. Identify types of plating.
- 1-2. Identify steps in can fabrication.
- 1-3. Identify can styles.
- 1-4. Identify types of can enamels and coatings.
- 1-5. Identify can labeling methods.
- 1-6. Identify how to measure can sizes.
- 1-7. Identify methods of thermal processing.
- 1-8. Identify types of retorts.
- 1-9. Identify methods of cooling cans.
- 1-10. Identify the purposes of commercial sterilization.
- 1-11. Identify the characteristics of a glass container.
- 1-12. Identify the characteristics of the tray pack.
- 1-13. Identify the characteristics of a retort pouch.
- 1-14. Identify parts of a can, a glass container, the tray pack, and a retort pouch.

### **SUGGESTION**

After studying the assignment, complete the exercises at the end of this lesson. These exercises will help you to achieve the lesson objectives.



## LESSON 1

### INTRODUCTION TO FOOD CONTAINERS

#### 1-1. INTRODUCTION

a. **Canning.** For a number of years now, perishable foods have been preserved in metal or glass containers using a thermal process (heat treatment) to achieve commercial sterility, which leaves the food product free of viable microorganisms. These containers are hermetically sealed; that is, they have an airtight seal designed to secure against the entry of microorganisms. Canning may be defined as the preservation of perishable foods in containers, to include a hermetic seal, after having been subjected to a heat treatment adequate to destroy those organisms hazardous to human health.

b. **Necessary Knowledge.** The veterinary food inspection specialist must be familiar with various aspects of the can manufacturing process in order to understand the terms and concepts involved. This knowledge will be needed when cans are inspected for defects. In addition, some familiarity with glass containers, "tray pack" cans, and retort pouches will be needed.

#### 1-2. CAN LINE

Cans are made on a series of machines collectively known as a can line. This is a continuous process from the entrance of the sheets of tin plate at one end of the can line to the emergence of the completed and tested can at the opposite end. Veterinary food inspection specialists must have a general knowledge of this process to understand can defects.

#### 1-3. PLATING

a. **Steel Base Plate.** The steel base plate is the sheet of steel that forms the base for the fabrication of metal containers. It is usually 0.01 inch thick. Specifications require that cans will be made from plates having a base box weight of not less than that in common commercial use for the specific product, style, and size of can. (The base box is a merchandising unit used for transactions in the tin plate industry. The unit consists of 112 sheets of tin plate, the dimensions of which are 14 by 20 inches.)

b. **Tin-Plating.** Tin-plating is a process by which a thin film of pure tin is deposited over both sides of the steel base plate. (See Figure 1-1). A 1.0-pound tin plate has a film of tin 0.000065 inch in thickness and contains as many as 8,000 pores per square centimeter. Therefore, it can be seen that the film of tin on a tin can is not impervious; that is, it does not prevent the content of the can from penetrating through to the steel. The presence of these pores requires the application of enamels and coatings to further protect the cans and the product. As a matter of information, pure tin

is not actually pure, but contains up to 1 percent lead. The tin should not contain more than 1 percent lead; otherwise, it will darken on exposure to the atmosphere.

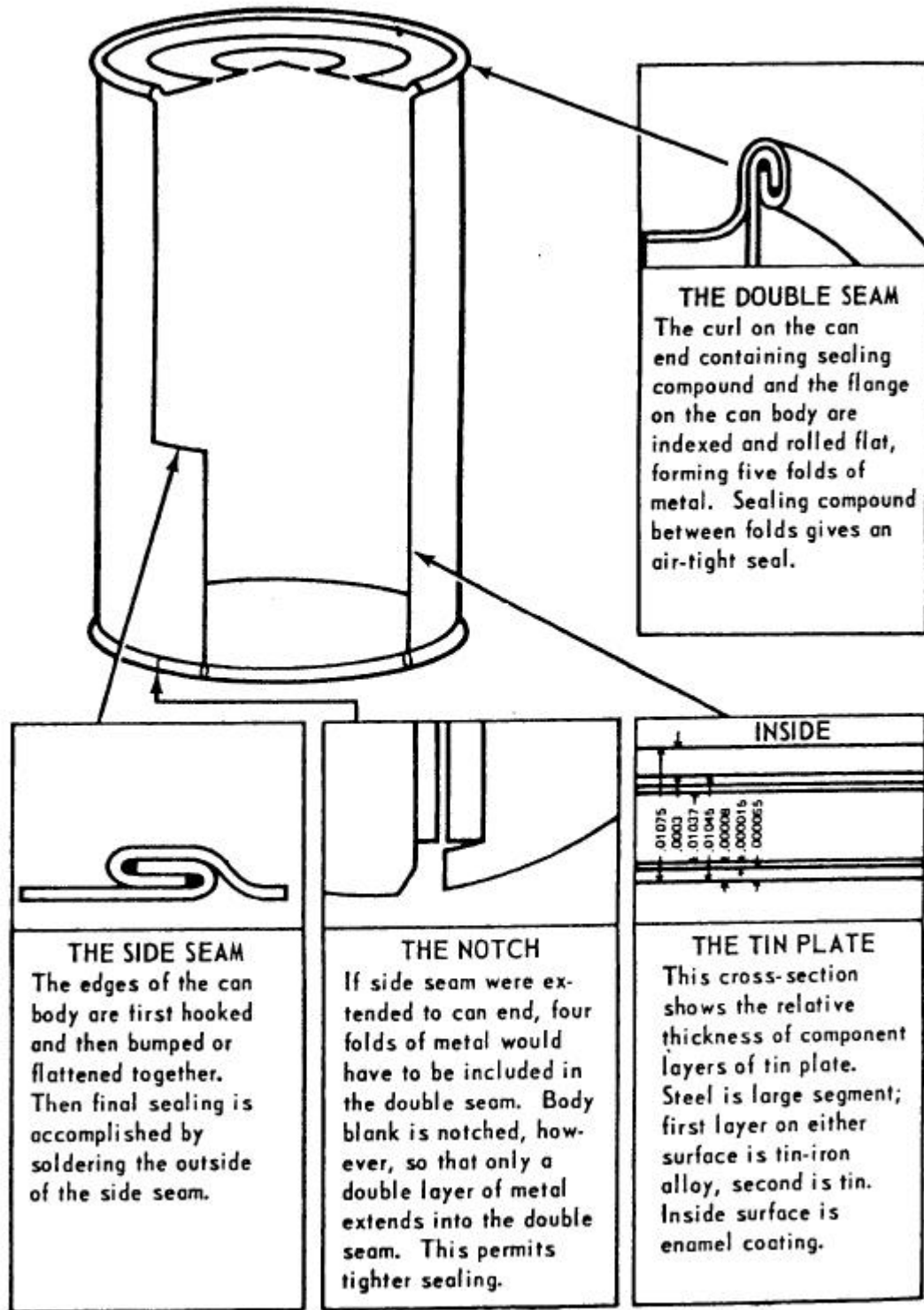

Figure 1-1. Can fabrication showing tin plate thickness and seam formation of a sanitary can.

c. **Types of Plating.** Cans are made from sheets of steel that are tin-plated, then enameled and labeled. There are several types of plating.

(1) Electrolytic plating. This is the most common method of plating. Tin is the anode, the steel base plate is the cathode. Both are suspended in a concentrated solution of a tin salt, and tin is deposited with large electric currents on the steel base plate by ion transfer. The thickness of the coating is controlled by the length of time the sheet is in the solution. After tinning, the sheets are heated and rolled to ensure a uniform tin film. Electrolytic plating can be recognized by the presence of fine, straight, parallel lines on the surface. This type of plating requires only about a third as much tin as a comparable hot dipped sheet.

(2) Differential plating. In this process, more tin is deposited on one side of the base plate than on the other. The heavier surface is used on the interior of the can.

(3) Hot dipped. In this rarely used method, sheets of steel base plate are dipped into vats of molten tin as often as necessary to produce the desired thickness of tin coating. Hot-dipping tin can be recognized by the presence of treeing (the successive layers of tin plate form a crystalline pattern).

#### 1-4. STEPS IN CAN FABRICATION

The tin has been applied to the steel base plate during the plating process to make what is known as the tin plate.

a. **Step A. Initial Sizing and Cutting.** The first step is the slitting of the tin plate into body shanks which yields can bodies with the desired dimensions and the notching and beveling of the body blank. Notching and beveling reduces the layers of metal incorporated in the can ends. Notching is cutting slits on one side 1/16-inch deep and 1/8-inch from each edge (Figure 1-2A).

b. **Step B. Preparing the Edges.** The next step is the bending and hooking of the notched and beveled sides. The notched and beveled sides are bent directions to form hooks (Figure 1-2B).

c. **Step C. Shaping the Can.** Next the body is formed around a steel mandrel of the desired shape and the hooks are interlocked (Figure 1-2C).

d. **Step D. Preparing the Side Seam.** During the next step, called bumping, the hooked areas are hammered together to form the side seam (Figure 1-2D). This bumping does not completely flatten the seam. This bumping is followed by fluxing and soldering. Fluxing is done to remove any oil or excess enamel or other impurity from this area. In the soldering operation, hot solder is allowed to run into the seam to coat all the tin plate area therein. Following this, a second bumping occurs while the solder is still hot to completely compress the side seam and form a hermetic seal (Figure 1-2E).

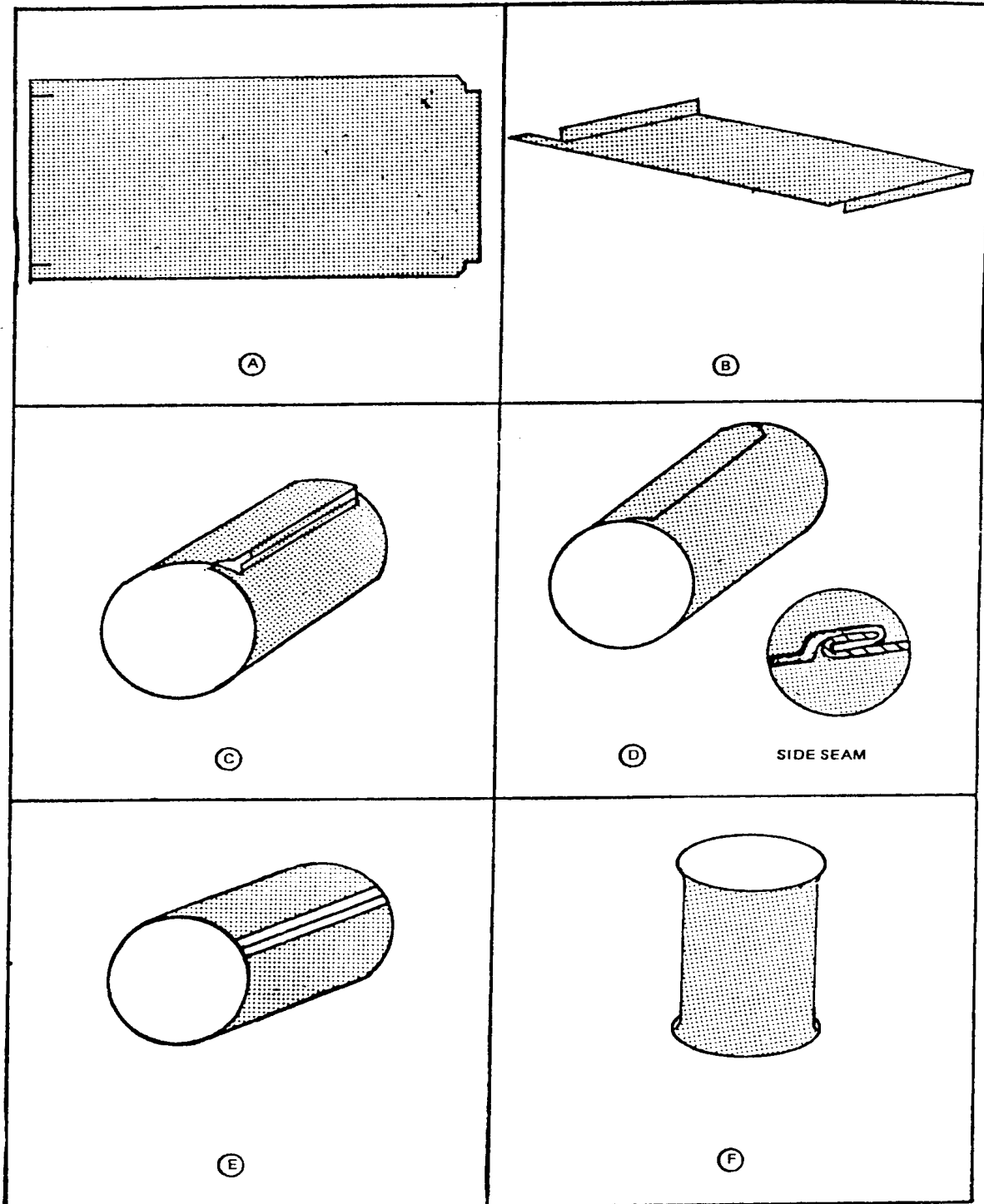

Figure 1-2. Can fabrication.

e. **Step E. Attaching the End of the Can.** The next step is the application of the end of the can to the body and includes flanging of the body (Figure 1-2F). During this step, the outer edges of the cylinder formed around the mandrel are turned outward toward a 90 degree angle. The end is formed to fit over and around this flange by being pressed out of tin plates. The portion of the end that fits around the flange is called the cover curl. This curl is filled with rubber base gasket compound that will form a hermetic seal when the cover curl is bent around the flange (Figures 1-1 and 1-3).

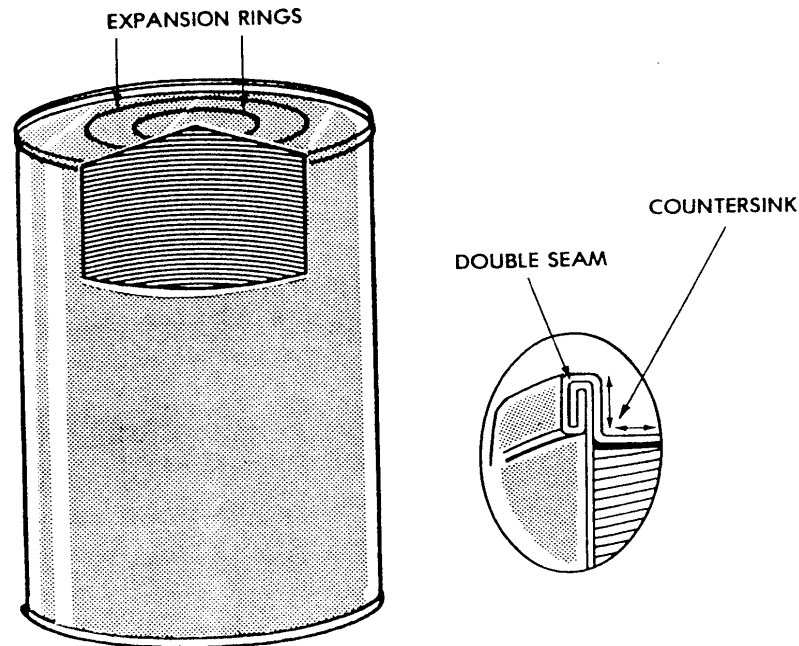

Figure 1-3. Can end.

f. **Step F. Preparing the Double Seam.** The final step is formation of the double (end) seam. This formation is performed by two rollers, which revolve around the can pushing the flange downward and compressing the cover curl completely around the flange. The first operational roll lightly rolls the cover curl and the flange together and the second operational roll tightly presses the two together to form a hermetic seal and the double (end) seam. The end applied to the can at the can manufacturing plant is called the manufacturer's end whereas the end applied after the product is in the can is called the packer's end.

## 1-5. BEADING

Larger size cans that tend to have weaker bodies may be beaded. Beading is a method of strengthening a can by reinforcing ribs or concentric depressions around the body. (See Figures 1-4 and 1-9.) Beading increases the resistance to paneling. Paneling is caused by excessive exhausting following the filling operation and causes inward movement of the can sides.

## 1-6. VACUUM IN THE CAN

Prior to application of the packer's end, a vacuum is applied to the headspace. (Headspace is the nonfilled portion of a container that allows for product expansion. A vacuum is the result of a process whereby air and/or free gases are removed from the container.) Vacuum is applied for numerous reasons, but primarily to prevent bacterial growth. Other important reasons for a vacuum are to prevent oxidation or rancidity of the product, preserve vitamins, and to provide space for expansion of gases during retorting. A vacuum can be drawn on the can by vacuum closing machines, preheating the product, using an exhaust box, or by injecting steam into the headspace of the can.

## 1-7. CAN STYLES

The can style varies with the product it is to hold. The ends are differentiated as manufacturer's end (put on during fabrication) and packer's end (put on by the contractor after the can is filled, normally with embossing, showing can code information). Can styles have been given names according to the characteristics of the can. See Figure 1-4. Some of the different kinds of can styles are:

- a. **Sanitary (Open Top).** These are round in the cross section and have double-seamed ends. A sanitary can is always sterilized after it has been packed and sealed. This is the most common style of can in use today.
- b. **Extruded (Drawn).** Cans that are round, oval, or oblong in cross section are extruded cans. These have a one-piece, drawn body, have only one double-seamed end, and have either a crimped-on or a soldered-on end. The lid may be scored for opening with a key or finger pulling. Some items packed in extruded cans are sardines, anchovies, herring, jellies, desserts, and military rations.
- c. **Square, Rectangular, or Oval.** Some cans are square or rectangular in cross section and have double-seamed or soldered-on ends. These cans are commonly used for luncheon meat, hams, loaf-type items, and survival packets. The oval cans are also known as pear-shaped cans.
- d. **Hole and Cap or Vent Filler.** These cans are square, round, or rectangular in cross section. They have double-seamed or soldered-on ends, and are used to package evaporated milk and anhydrous milk fat. The final closure is a soldered cap or a vent hole filled with solder.
- e. **Beaded Cans.** These have indented grooves around the circumference of the can body that are parallel with the double seam. Beading increases resistance to paneling by up to 150 percent. It is used mainly on larger cans that tend to have weaker bodies.

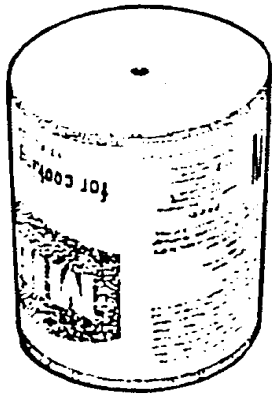

HOLE & CAP  
OR VENT FILLER

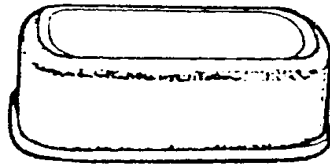

EXTRUDED  
(DRAWN)

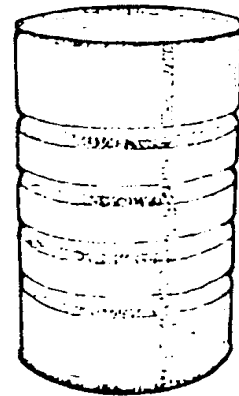

SANITARY  
(OPEN TOP)

OVAL  
(PEAR-SHAPED)

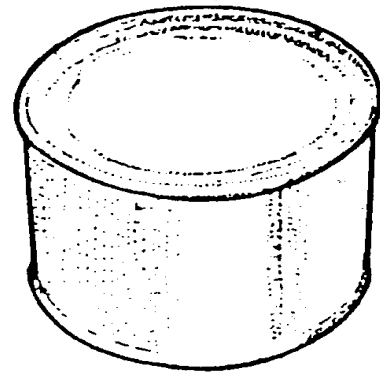
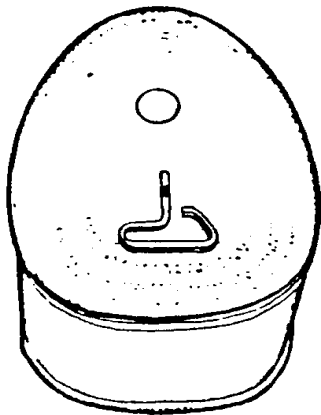

Figure 1-4. Can styles.

## 1-8. ENAMELING AND COATING

The tin base must be treated to further protect the product and to protect from adverse product reaction to the can. To further protect the steel base, enamels are applied to the inside surface and coatings are applied to the outside surface of the can, prior to can fabrication.

a. **Enamels.** Can enamels are the paint-like composition baked onto the interior of cans to prevent the production of hydrogen gas and to prevent or inhibit unfavorable reactions between the can and its content. They are inert, adhere tightly to the tin plate, and will withstand stress. The type of enamel used is dependent upon the product to be put into the can.

b. **Coating.** Coatings are the nontoxic, external paints, or enamels that are applied for the purpose of preventing corrosion and providing camouflage. Coatings must be nontoxic and must meet specification requirements, as required. The coatings are precoated or postcoated. Precoated coating refers to a coating applied to the exterior flat sheets of tin plate prior to fabricating the tin plate into cans. Postcoated coating is applied to the exterior of food cans after they have been filled with food, sealed, and processed.

## 1-9. CAN LABELING METHODS

Can labeling serves to identify the contents of the can as to contents, weight, manufacturer, and processing plant. The labeling used on containers depends on the product and its intended use.

a. **Lithographing.** Lithographing is printing which has been baked to the surface of the tin by heat treatment. It is accomplished prior to coating the can. The labeling is usually placed on the packer's end of the can but in some instances, it may be on the can body. This process is often used for operational rations.

b. **Stamping.** Stamping is the application of marking with an inked stamp. It is not bonded to the surface of the tin with heat, although it may be subjected to heat in order to speed drying.

c. **Embossing.** In embossing, the markings are raised in the tin plate of the can end or of the body. These markings must not be sharp or have well-defined edges. The embossing procedure must be carefully controlled to ensure legible markings without "harming" the can. Can codes are usually embossed on the packer's end of the can.

d. **Paper Labels.** Paper labels are permitted for domestic shipments on military contracts. They are rarely used on products that are shipped overseas because the glue tends to hold moisture in close contact with the can, resulting in corrosion.



## **1-10. CODING**

A group of numbers or letters are stamped or embossed on the can end, or body. The coded information may include: the item, date of pack, and shift during which it was packed. If the code is embossed, it is done just before the can is sealed. This is one way to identify the packer's end of the can from the manufacturer's end.

## **1-11. MEASUREMENT OF CAN SIZES**

The size of a can is dependent upon the consumer's demand and the dimension of the product. Certain trade names, such as "number ten," "number two-and-a-half," and "number three-O-three" have been applied to common can sizes to the extent they are now household terms. (See Figure 1-5.) Its use is not mandatory but has received wide acceptance in the trade. The system is used almost exclusively for designating can sizes in federal and military specifications. All measurements are to the nearest 1/16th of an inch and are taken at the extremes of the double seams. Measurements are stated in numbers of three or four digits. The first one or two digits in the number represent the number of whole inches; the last two represent the number of fractional sixteenths. For example, a can that is 3 inches in diameter by 4 and 8/16 inches in height is designated numerically as 300 by 408. A can 4 and 8/16 inches in diameter by 10 and 12/16-inches in height is designated numerically as 408 by 1012. It is important to remember that we record only the numerator of the fraction, which is in sixteenths. Also the measurements are always to the extreme outer edges of the can.

<u>Can Size</u>	<u>Trade Name</u>
202 x 204	2Z Mushroom
202 x 214	5Z Baby Food
202 x 308	6Z Jitney
202 x 314	6 1/2 Z
211 x 109	1/4 lb. Tuna
211 x 210	211 Baby Food
211 x 200	4Z Pimento
211 x 212	4Z Mushroom
211 x 300	8Z Short
211 x 304	8Z Tall
211 x 400	No. 1 Picnic
300 x 206	7Z Pimentos
300 x 400	8Z Mushroom
300 x 407	No. 300
301 x 411	No. 1 Tall
303 x 406	No. 303
307 x 113	1/2 lb. Tuna
307 x 306	No. 2 Vacuum
307 x 400	No. 95
307 x 409	No. 2
307 x 510	Jumbo
307 x 704	Quart Olive
307 x 710	32Z (Quart)
401 x 206	No. 1 1/4 (Vegetable)
401 x 411	No. 2 1/2
404 x 307	No. 3 Vacuum
404 x 414	No. 3
404 x 700	No 3 Cylindrical (46Z)
502 x 510	No. 5
603 x 408	No. 5 Squat
603 x 700	No. 10
603 x 812	No. 12 (Gallon)

Figure 1-5. Common trade names for round cans.

a. **Round Can.** This type can has two measurements: diameter and height. The can size will be designated by two sets of three- or four-digit numbers. The first number is the diameter of the can and the second number is the height of the can. See Figure 1-6.

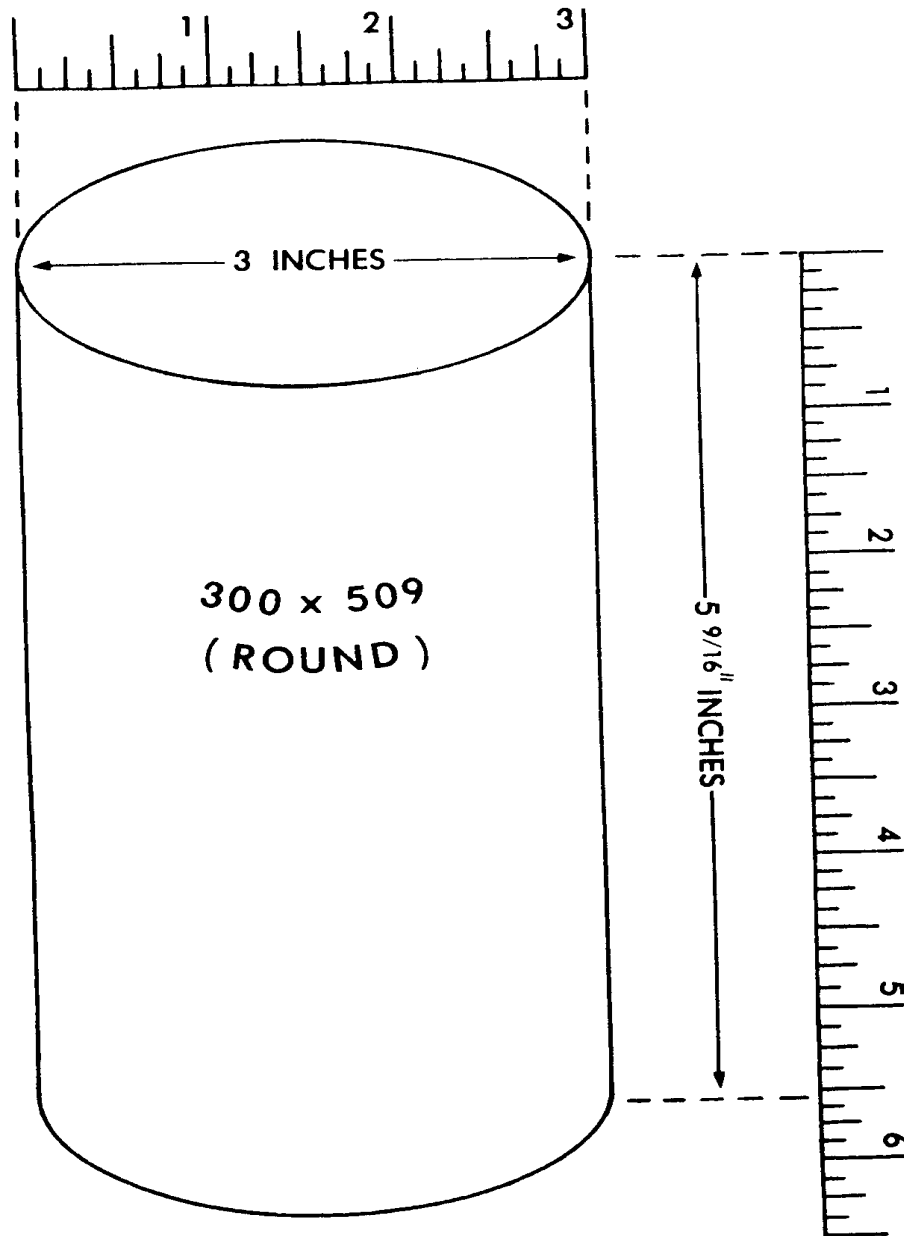

Figure 1-6. Measuring the size of a round can.

b. **Square or Rectangular Cans.** These cans have three measurements. The first measurement recorded is the longest measurement of the can end, the second number is the shortest measurement of the can end, and the third number is the height of the can. The height measurement is from the manufacturer's double seam (bottom of the can) to the packer's double seam (top of the can). Thus, the can size is designated by three sets of numbers and recorded in the following order: 402 (4 and 2/16 inches, the longest can end measurement) by 303 (3 and 3/16 inches, the width of the can end) by 1012 (10 and 12/16 inches, the can height). (See Figure 1-7.)

208 x 111 x 408  
( RECTANGULAR )

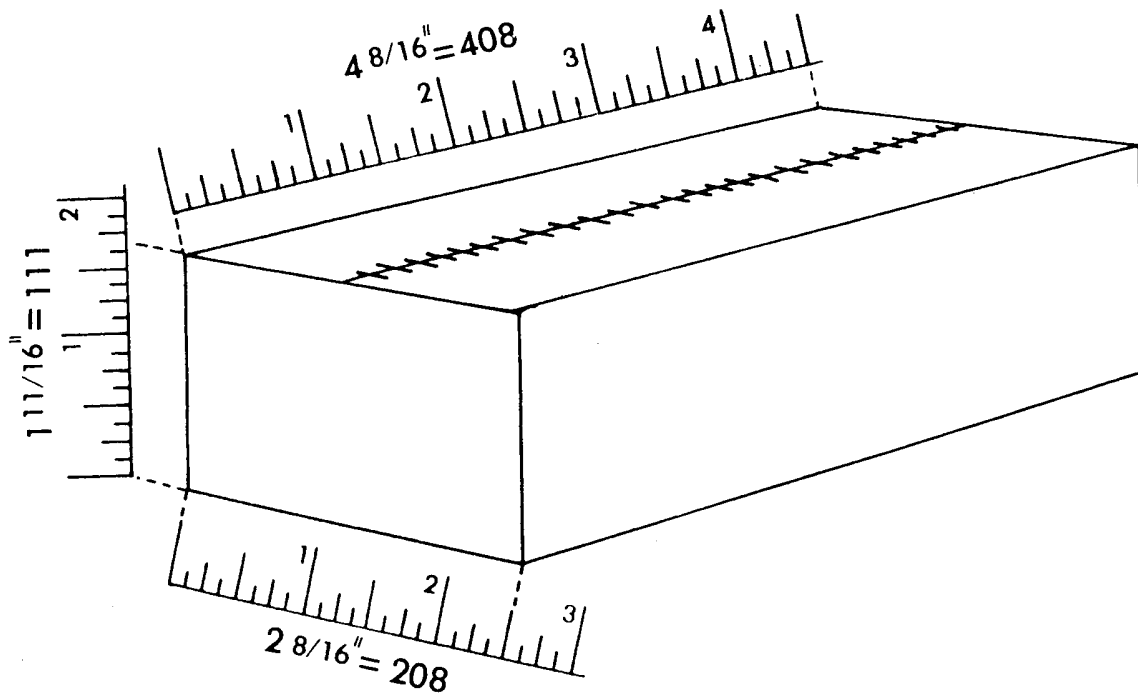

Figure 1-7. Measuring the size of a square or rectangular can.

c. **Oval Cans.** Oval or pear-shaped cans also have three measurements that are recorded in order of the longest measurement of the end, then the shortest measurement, and finally, the height of the can (double seam to double seam). The size of an oval can is recorded using three sets of numbers (length x width x height). For example, 402 (4 and 2/16 inches) by 303 (3 and 3/16 inches) by 208 (2 and 8/16 inches). In addition, to distinguish this size can from a rectangular can, the numerical designation is followed by the parenthetic term (oval) or (pear-shaped)--for example, 402 X 303 X 208 (oval). (See Figure 1-8.)

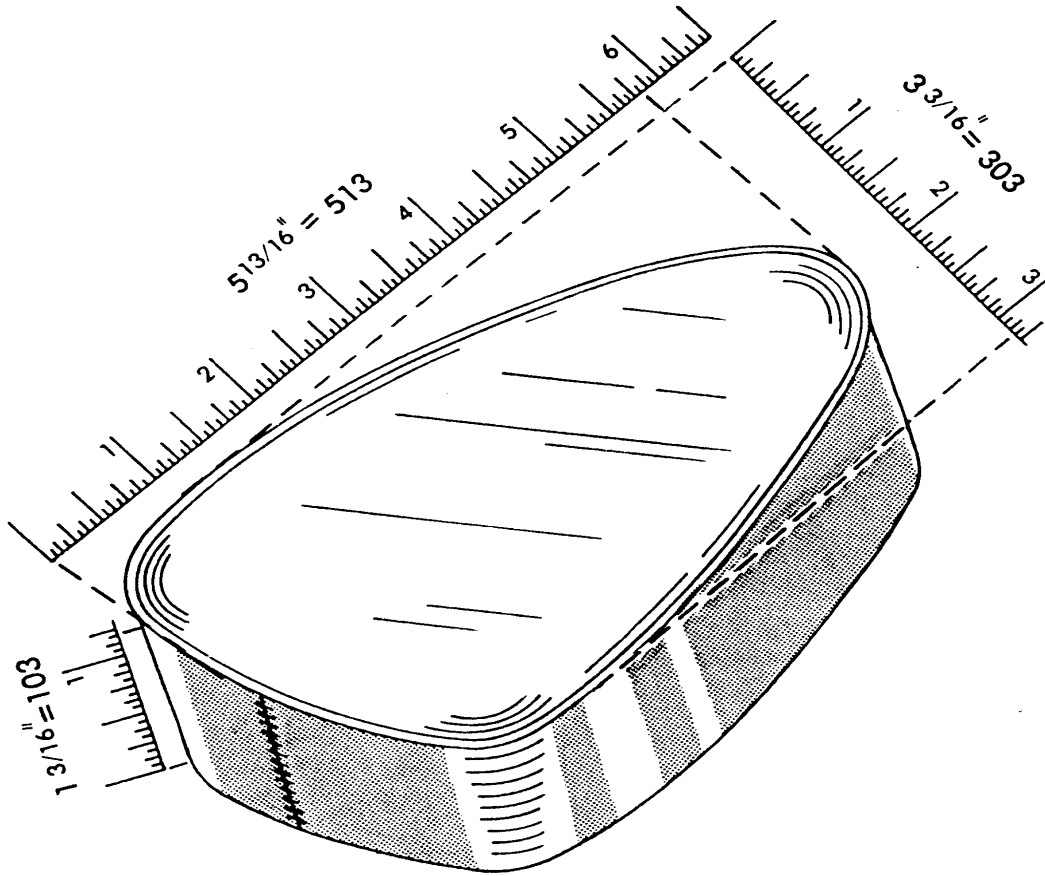

Figure 1-8. Measuring the size of an oval (pear-shaped) can.

## 1-12. THERMAL PROCESSING

Food is prepared for canning and placed in containers. High-acid foods are processed with moderate heat treatment, since the acid itself inhibits bacterial growth. Low-acid foods require a much higher temperature. Times and temperatures are usually given in the contractual documents. A vacuum is created in the container by one of several methods.

a. **Vacuum Closing.** In this method, machines are used to close cans of cold-pack products in a vacuum chamber (example, canned ham).

b. **Preheating.** The product is heated to 165°F (74°C) or above and held at the temperature during packing. The heat expands the can's contents. After the contents are retorted and cooled, they contract and produce a vacuum.

c. **Exhaust Box.** This method, sometimes called exhausting, uses a tunnel in which filled cans are heated, causing the contents to expand. After they are retorted and cooled, they contract and produce a vacuum.

d. **Steam Jet (Steam Vac).** Live steam at 250°F (122°C) is injected into the headspace of the filled can until the end is double-seamed into place. The steam condenses as it cools, creating a vacuum.

## 1-13. RETORTING

Immediately after the air has been exhausted, the can is sealed by machine. The filled can is then placed in the retort for thermal processing. A retort is any closed vessel or other equipment used for thermal processing at high temperatures (greater than 212°F). This processing has two purposes: to produce a commercially sterile product and to cook the material so that it can be consumed with a minimum of further preparation. An example of a retort is a pressure cooker.

a. **Vertical Retort.** The vertical retort consists of a large pressurized steam cooker that either sits on the floor (for a single batch processing) or extends beneath the floor (for processing several batches at a time). It is loaded and unloaded from the top.

b. **Horizontal Retort.** Essentially, this is a vertical retort that has been positioned on its side and modified to admit steam along the length of the top side. It is loaded from the end.

c. **Continuous Retort.** This is the most modern unit and is now used in many commercial plants. Its three sections are the preheater, the cooker, and the cooler. Each unit contains a revolving reel and a spiral track. The cans are continuously fed into individual compartments of the retort and rotated by movement of the reel while, at the same time, the track guides them continuously from inlet to outlet.

## 1-14. COMMERCIAL STERILIZATION

Commercial sterilization of low-acid food is that process by which all Clostridium botulinum endospores and all other pathogenic microorganisms are destroyed, as well as microorganisms which could produce spoilage under conditions of normal, nonrefrigerated storage and distribution in sealed containers. Some bacteria produce endospores of extremely high heat resistance. These cannot be destroyed without processing to such a high degree that the product would be unmarketable. Fortunately, these bacteria are not pathogenic and are unable to germinate and cause spoilage at temperatures below 100°F (38°C).

## 1-15. COOLING

After the heat processing, the cans are cooled. This is done rapidly to prevent undue softening of the texture or change in color of the product. One of the following two methods is used:

a. **Air Cooling.** Cans are piled in rows in a well-ventilated, specially designed warehouse that has ample space for efficient air circulation. The heat is dissipated into the surrounding air. This method has a slower loss of heat than the water-cooled method.

b. **Water Cooling.** There are several kinds of water cooling, based on one of two procedures. Cold water may be admitted to the retort after the processing is complete, or the cans may be removed from the retort and conveyed through tanks or showers of cold water. Large sizes or irregular-shaped cans must be pressure-cooled in a closed retort to avoid undue strain on the containers.

## 1-16. PARTS OF A CAN

The parts of a can may be noted in Figure 1-9. Most of the parts identified have been discussed in earlier paragraphs. The parts are: the side seam, the body, the bead, the key tongue, the score, the can end, the double seam, the countersink, the expansion ring, and the can code.

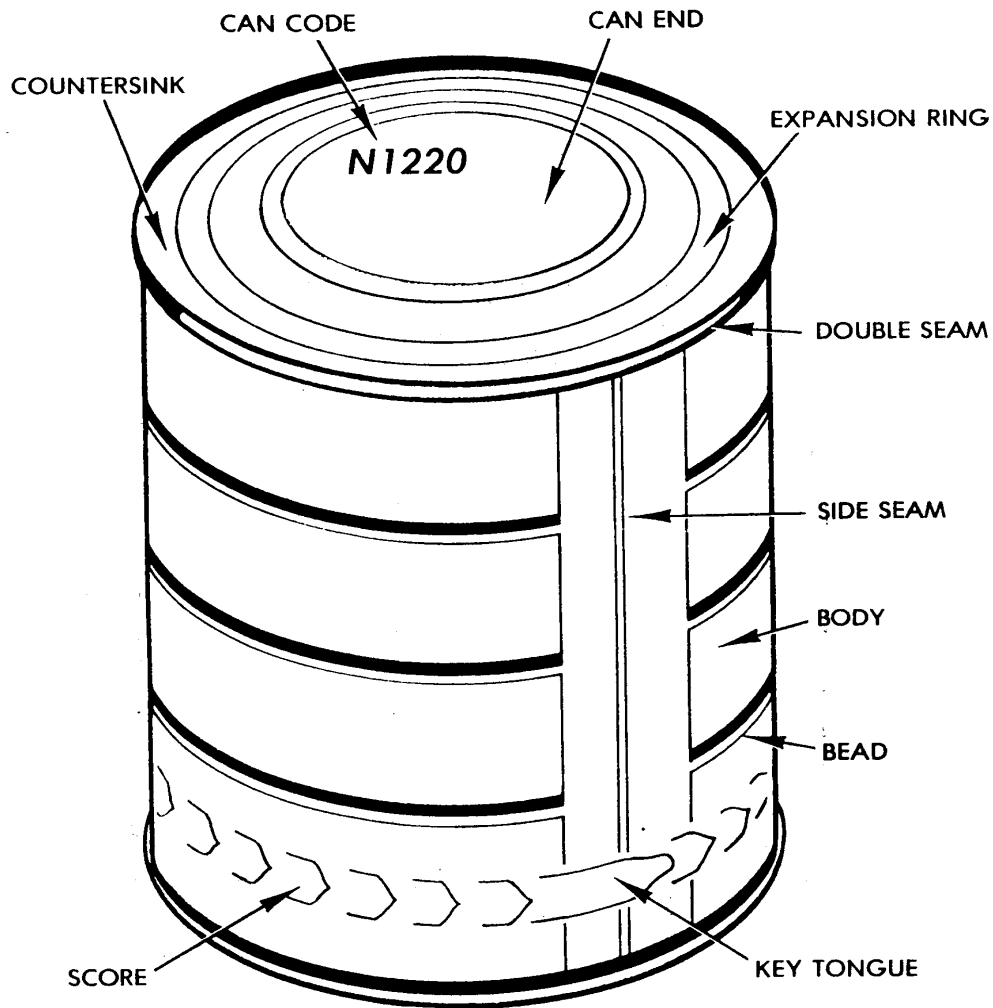

Figure 1-9. Parts of a can.

## 1-17. GLASS CONTAINERS

Modern technology permits the production of glass that is competitive with other container materials in function and strength. Components of a glass food container are the body, the bottom, and the closure. See Figure 1-10. The finish is that part of the glass container that holds the cap or closure. The glass lug is the threads or glass protrusions found in the area of the finish, which are used to hold on the closure. Glass containers are not harmful to food products, but the closures may be. It is sometimes difficult to find material that seals to the required tightness, is inert to the product, and can be stored satisfactorily.



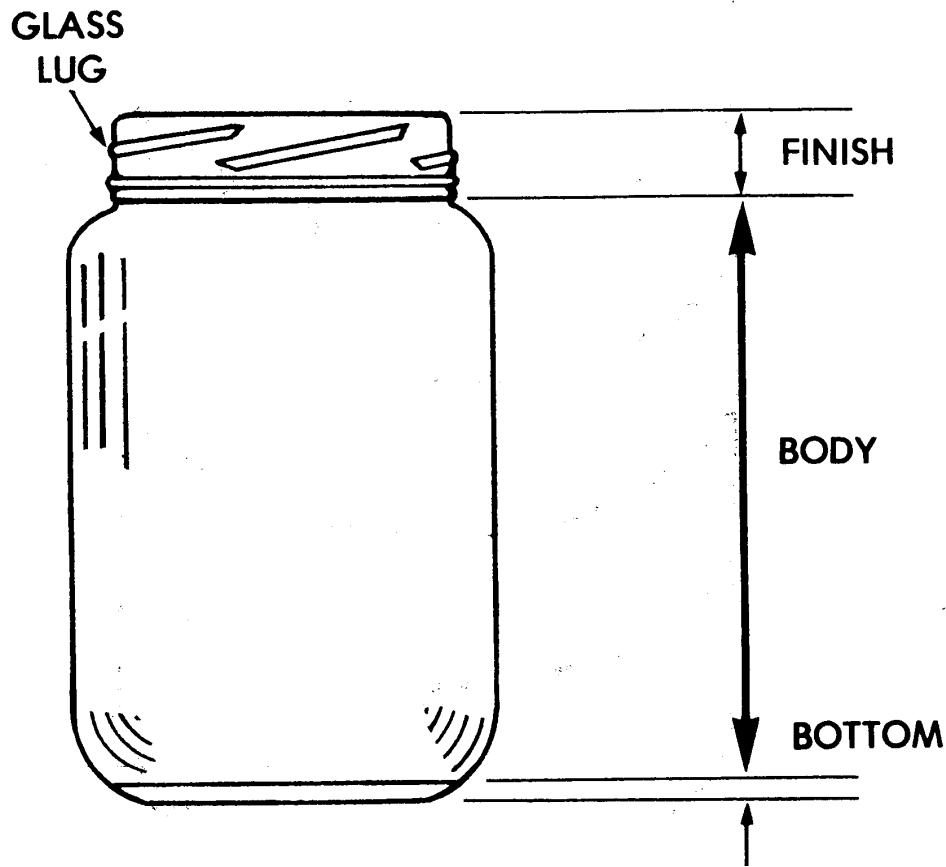

Figure 1-10. Parts of a glass container

## 1-18. THE TRAY PACK

a. **Characteristics.** The tray pack can, also called the half-size steam table tray, is a low-profile, two-piece, retortable, institutional-size container. See Figure 1-11. It is extruded from chromed steel plate and layers of chromium, chromium oxide, and a base of epoxy. It is enameled with modified vinyl inside and out. The dimensions are 9 7/8 inches x 12 1/4 inches x 2 inches. The capacity is about the same as a Number 10 can (603 x 700), holding 105 ounces of food. The lid is double seamed like a standard 3-piece cylindrical can. Due to its low profile, retort process times for the tray pack may be reduced as much as 60 percent. The geometric center is only about 1 inch as compared to 3 inches for the Number 10 can.

b. **How Used.** The tray pack can serves as a shipping container, heating container, and serving container, thus reducing the amount of time, labor, equipment, and skill needed for preparing and serving meals in a field environment. The tray pack has become an integral part of the new Combat Field Feeding System. The new system, consisting of 14 breakfast menu entrees and 14 lunch/dinner entrees, will be used in place of the standard B-Ration.

c. **Durability.** The configuration of the tray pack can makes it much less durable than the cylindrical Number 10 can; therefore, it is much more susceptible to mechanical damage during transportation, handling, and storage. Under normal conditions, the tray pack should last 3 years.

d. **Landmarks of a Tray Pack Can.** The characteristic parts of a tray pack can may be noted in Figure 1-11. Easily identifiable are the double seams, the fluted corners, reinforcement beads, and the labeling surface on the top.

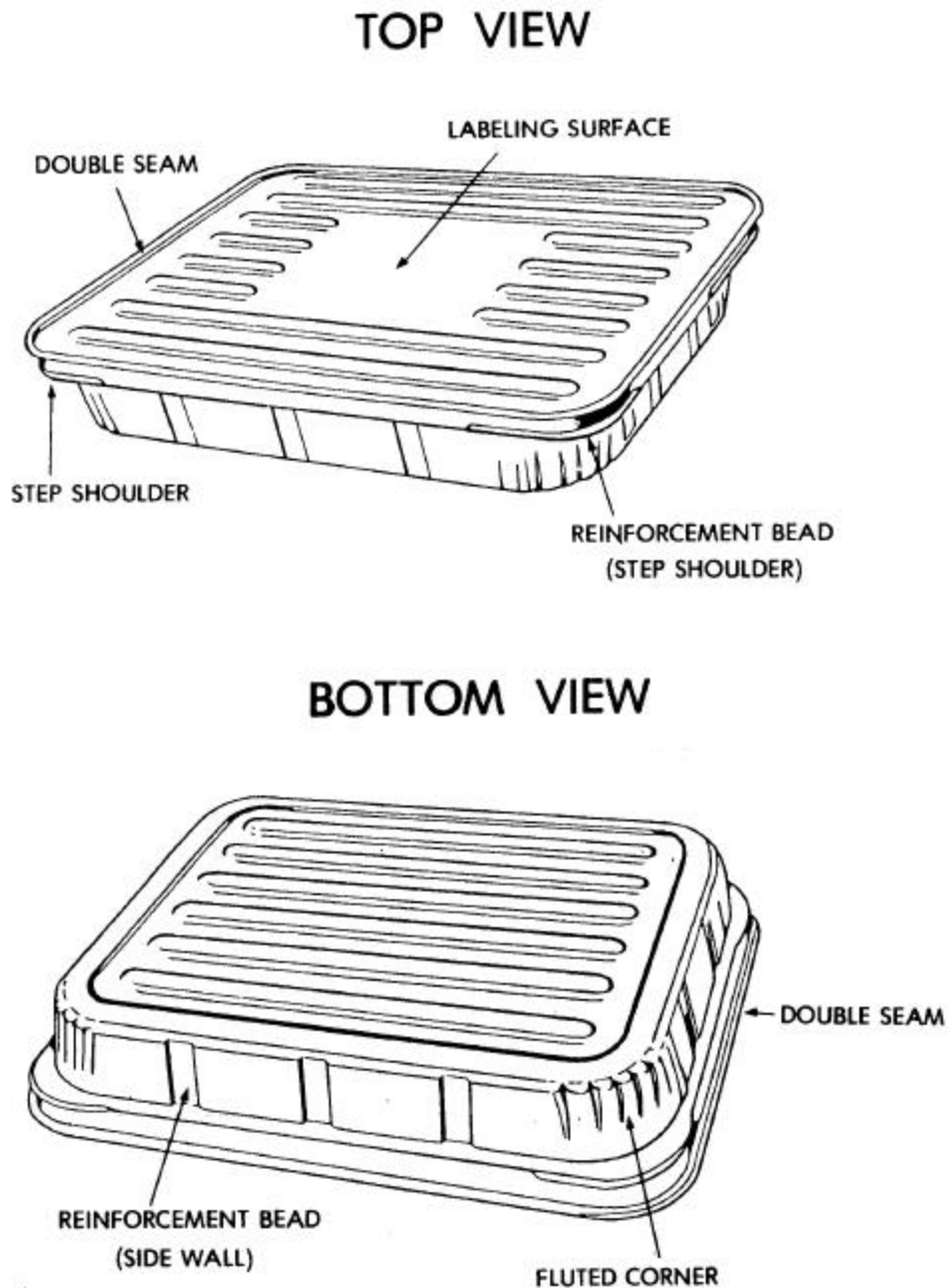

Figure 1-11. Parts of a tray pack can.

## 1-19. RETORT POUCHES

a. **Characteristics.** The retort pouch is a flexible, heat sealable container that is thermally processed like a can and may be used to produce shelf stable, commercially sterile food products. It is constructed of a 3-ply laminate composed of an outer layer of polyester film, a middle layer of aluminum foil, and an inner layer of polypropylene. The layers are bonded together with an epoxy adhesive. The poly laminate material provides seal integrity, toughness, puncture resistance, and superior barrier properties for long shelf-life. It also withstands the rigors of thermal processing up to 275°F (135°C). Much of the retort pouch development was conducted by the U.S. Army Natick Research and Development Center for use in the Meal, Ready-to-Eat (MRE), an individual operational ration.

b. **Specific Dimensions.** Each layer of this poly laminate has a specific function. The outer polyester film is approximately 0.0005 inch thick and resists scuffing, flexing, and other mechanical damage. The flex resistance prevents flex cracking in the aluminum foil layer. The middle aluminum foil layer is 0.00035 inch thick and acts as a gas, light, and moisture barrier. The inner polypropylene layer is 0.0003 inch thick and is the inert food contact layer, which also provides the fusion bonded seal when heat and pressure are applied.

c. **Advantages and Disadvantages.** The retort pouch offers several advantages over the steel tin-plated can. Shorter retort times may be used due to its flat configuration and shorter distance to the geometric center. Due to the inert properties of the pouch materials, chemical corrosion of the interior and exterior surfaces is almost nonexistent. The retort pouch also weighs less than the steel tin-plated can. Some of the disadvantages include a lack of physical durability and slow production rates.

d. **Parts of a Retort Pouch.** The parts of a retort pouch may be noted in Figure 1-12. The parts are: the lip, the tear notches, the final seal (at the top), the side seal, and the bottom seal.

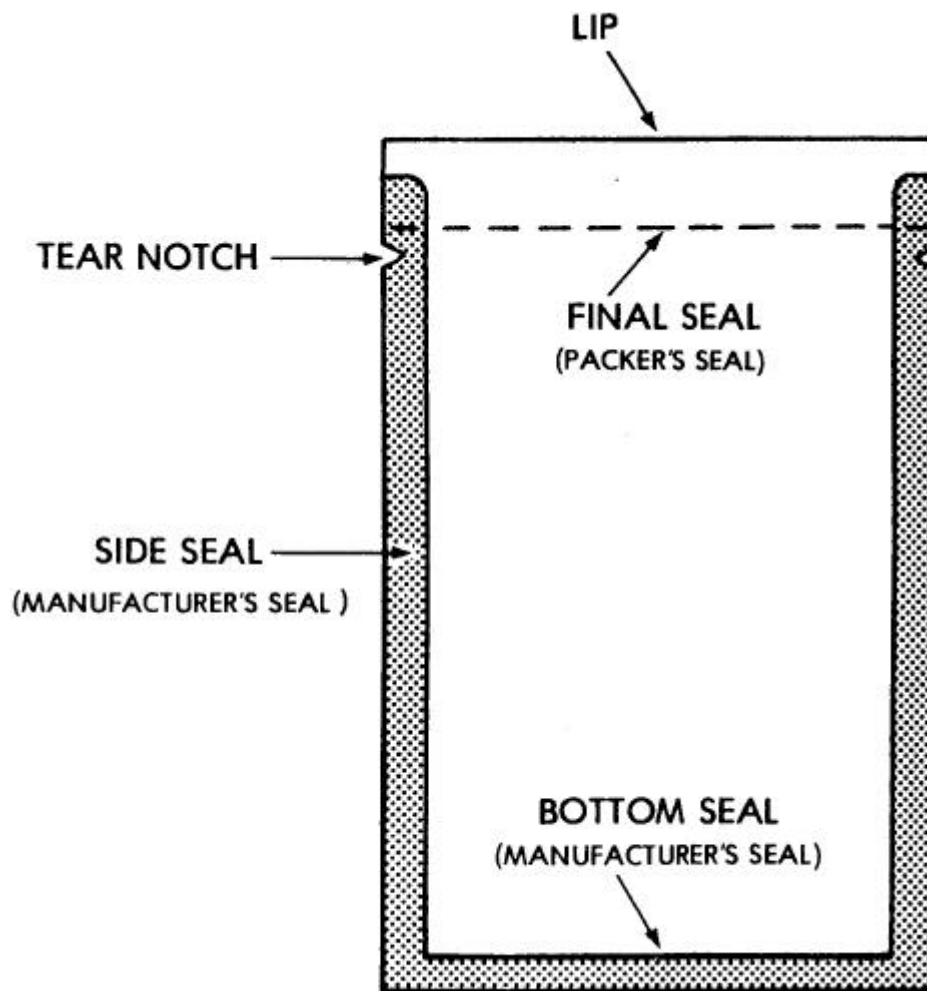

Figure 1-12. Parts of a retort pouch.

*Continue with Exercises*

## EXERCISES, LESSON 1

**REQUIREMENT.** The following exercises are to be answered by marking the lettered response that best answers the question, or by completing the incomplete statement, or by writing the answer in the space provided at the end of the question.

After you have completed all the exercises, turn to "Solutions to Exercises" at the end of the lesson and check your answers with the Academy solutions.

1. In the canning industry, the term commercial sterilization means that:
  - a. A product has been processed to make it completely sterile.
  - b. A product has been processed to destroy or inhibit most spoilage organisms.
  - c. A product has been processed for a least 3 hours at 212°F (100°C).
  - d. Commercial canning has been done under sterile conditions.
  
2. Hermetically sealed is the term used in the canning trade to indicate that:
  - a. The can has been sealed after all the air has been expelled.
  - b. The can and contents have been heat treated.
  - c. The can has been sealed after the excess air has been expelled.
  - d. The can is airtight.
  
3. The most common method of tin-plating is \_\_\_\_\_ plating.
  
4. What is the purpose of enamels in the can-making process?
  - a. Provides camouflage for the can.
  - b. Provides a thin coating of tin to the surface of the base plate.
  - c. Prevents or inhibits unfavorable reactions between the inside of the can and its contents.
  - d. Provides additional protection to the exterior of the can.

5. Why are can coatings used in the can-making trade?
- a. To prevent corrosion of the outside of the can.
  - b. To provide camouflage for the can.
  - c. To inhibit production of hydrogen gas in canned food.
  - d. To provide additional strength to the body of the can.
  - e. Both "a" and "b" above.
6. Can coatings are used on the \_\_\_\_\_ of the can and can enamels on the \_\_\_\_\_ of the can.
7. List the steps involved in the fabrication of a can.
- Step A.
- Step B.
- Step C.
- Step D.
- Step E.
- Step F.
8. In can fabrication, the side seam is formed during the \_\_\_\_\_ process.
- a. Bumping.
  - b. Bending.
  - c. Hooking.
  - d. Notching.

9. A can end is applied firmly to the can body and sealed in place during:
- a. Bumping.
  - b. Bending.
  - c. Hooking.
  - d. Formation of the double seam.
10. A can is \_\_\_\_\_ in order to increase its resistance to paneling.
- a. Vent filled.
  - b. Dimpled.
  - c. Beaded.
  - d. Extruded.
11. How can a veterinary food inspection specialist distinguish the packer's end from the manufacturer's end of the can when he is examining canned foods?
- a. By the difference in the way the seams are made.
  - b. By the difference in size of the can ends.
  - c. By the label glued to the end of the can.
  - d. By the code embossed on one end of the can.
12. List the various ways cans are labeled to identify the contents.
- a. \_\_\_\_\_.
  - b. \_\_\_\_\_.
  - c. \_\_\_\_\_.
  - d. \_\_\_\_\_.

13. The correct recording of the size of a round can 3-3/16 inches in diameter and 5-9/16 inches in height is \_\_\_\_\_.

14. When recording can sizes, the last two numbers of a measurement represent \_\_\_\_\_ of an inch.

- a. Halves.
- b. Quarters.
- c. Eighths.
- d. Sixteenths.

15. Which of the can styles is identified by a can which is round and has double-seamed ends?

- a. Vent-filled.
- b. Dimpled.
- c. Extruded.
- d. Sanitary.

16. What is the main reason for applying vacuum to the headspace in a can?

- a. To prevent bacterial growth.
- b. To protect the product from acting on the can.
- c. To prevent the can ends from bulging outward.
- d. To protect the steel base plate.



17. List 4 methods of creating a vacuum in a container (thermal processing).

- a. \_\_\_\_\_.
- b. \_\_\_\_\_.
- c. \_\_\_\_\_.
- d. \_\_\_\_\_.

18. List 3 kinds of retorts.

- a. \_\_\_\_\_.
- b. \_\_\_\_\_.
- c. \_\_\_\_\_.

19. Identify the lettered part of the can shown below by placing the number of the corresponding part beside the letter on the illustration.

- |               |                   |                 |              |
|---------------|-------------------|-----------------|--------------|
| 1. Key tongue | 4. Side seam      | 7. Can end      | 10. Can code |
| 2. Bead       | 5. Double seam    | 8. Score        |              |
| 3. Body       | 6. Expansion ring | 9. Counter sink |              |

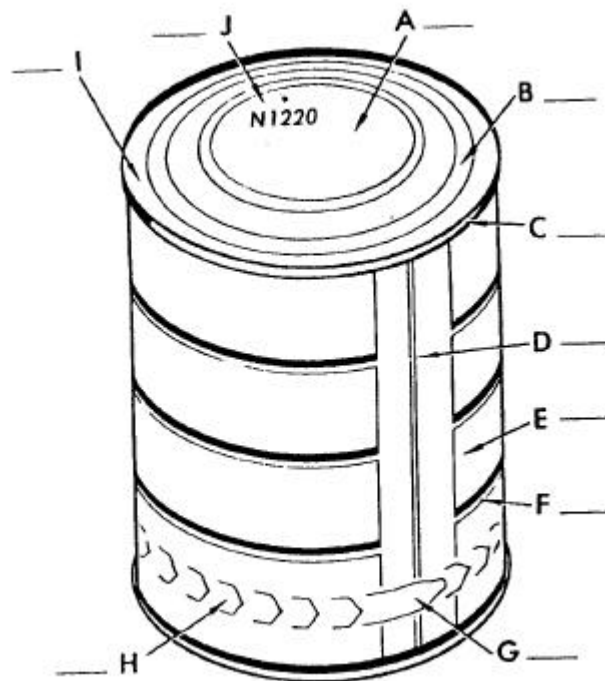

20. List two parts of the closure of a glass container.
- \_\_\_\_\_.
  - \_\_\_\_\_.
21. The capacity of the tray pack is about the same as a \_\_\_\_\_ can (603 x 700).
22. Menus served in tray packs are an integral part of the combat F\_\_\_\_\_ F\_\_\_\_\_ S\_\_\_\_\_.
23. Is the tray pack more susceptible or less susceptible to mechanical damage than the cylindrical Number 10 can?
- More.
  - Less.
24. The retort pouch was developed for use in the \_\_\_\_\_, \_\_\_\_\_(MRE), an individual operational ration.
25. List 4 advantages of the retort pouch over the steel, tin-plated can.
- Shorter \_\_\_\_\_.
  - Shorter distance to \_\_\_\_\_.
  - Almost no chemical corrosion of \_\_\_\_\_.
  - \_\_\_\_\_.

***Check Your Answers on Next Page***

## SOLUTIONS TO EXERCISES, LESSON 1

1. b (paras 1-1a; 1-14)
2. d (para 1-1a)
3. electrolytic (para 1-3c(1))
4. c (para 1-8a)
5. e (para 1-8b)
6. outside; inside. (para 1-8a and b)
7. Step A. Initial sizing and cutting.  
Step B. Preparing the edges.  
Step C. Shaping the can.  
Step D. Preparing the side seam.  
Step E. Attaching the end of the can.  
Step F. Preparing the double seam. (para 1-4)
8. a (para 1-4d)
9. d (para 1-4f)
10. c (paras 1-5 and 1-7e)
11. d (para 1-10)
12. a. Lithographing.  
b. Stamping.  
c. Embossing.  
d. Paper labels. (para 1-9)
13. 303 x 509. (para 1-11)
14. d (para 1-11)
15. d (para 1-7a)
16. a (para 1-6)
17. a. Vacuum closing.  
b. Preheating.  
c. Exhausting.  
d. Steam jet. (para 1-12)

18.
  - a. Vertical.
  - b. Horizontal.
  - c. Continuous. (para 1-13)
  
19.
  - a. 7 (can end)
  - b. 6 (expansion ring)
  - c. 5 (double seam)
  - d. 4 (side seam)
  - e. 3 (body)
  - f. 2 (bead)
  - g. 1 (key tongue)
  - h. 8 (score)
  - i. 9 (counter sink)
  - j. 10 (can code) (Figure 1-9)
  
20.
  - a. Finish.
  - b. Glass lug. (para 1-17)
  
21. Number 10. (para 1-18a)
  
22. Field Feeding System. (para 1-18b)
  
23. a (para 1-18c)
  
24. Meal, Ready-to-Eat. (para 1-19a)
  
25.
  - a. Shorter retort time.
  - b. Shorter distance to the geometric center.
  - c. Almost no chemical corrosion of the interior and exterior surfaces.
  - d. Weighs less. (para 1-19c)

**End of Lesson 1**

## LESSON ASSIGNMENT

### LESSON 2

Inspection of Food Containers.

### LESSON ASSIGNMENT

Paragraphs 2-1 through 2-18.

### LESSON OBJECTIVES

After completing this lesson, you should be able to:

- 2-1. Identify incubation and the purpose of incubation.
- 2-2. Identify why a vacuum is required in food containers.
- 2-3. Identify steps of procedure for determining vacuum.
- 2-4. Identify how to examine a food container.
- 2-5. Identify how dents are classified as container defects.
- 2-6. Identify external container defects due to internal pressures.
- 2-7. Identify external container defects due to seam defects.
- 2-8. Identify container defects due to external contamination.
- 2-9. Identify internal container defects.
- 2-10. Identify 3 categories of breakage of glass containers.
- 2-11. Identify characteristic surface markings of broken glass containers.
- 2-12. Identify glass container defects.
- 2-13. Identify retort pouch defects.

**SUGGESTION**

After studying the assignment, complete the exercises at the end of this lesson. These exercises will help you to achieve the lesson objectives.

## LESSON 2

### INSPECTION OF FOOD CONTAINERS

#### Section I. INCUBATION AND MEASURING VACUUM

##### 2-1. GENERAL

The veterinary food inspection specialist must know basic inspection skills for food containers. These include: (1) checking for a specific vacuum (when requirements so state), (2) receiving and acting on USDA reports after the adequacy of commercial sterilization has been determined by testing, (3) checking for a range of possible container defects of canned food items, glass containers, and retort pouches.

##### 2-2. INCUBATION

The U.S. Department of Agriculture (USDA) is the agency responsible for incubating samples of canned meats. It requires that representative sample cans from each retort be incubated 10 days at 90°F (32°C) to 100°F (38°C) to test the adequacy of commercial sterilization. The most desirable standard is to maintain a constant temperature of 98°F for the 10-day period. The inspector responsible for checking the incubation process may extend the 10-day period when he believes sanitary conditions in the processing or the condition of the machinery have deteriorated to such an extent that the prolonged period is necessary. The purposes of incubation are: to check the adequacy of processing, to assure acceptable or satisfactory commercial sterilization, and to assure the product will keep without refrigeration under normal conditions of storage and shelving. Food items that are processed without steam pressure cooking are deemed unacceptable for storage under normal conditions so they must be labeled "PERISHABLE-KEEP REFRIGERATED." Lots of a food item, samples of which are under incubation, may be shipped to the purchaser subject to being withdrawn from the market if incubation shows that the product is unacceptable for consumption.

##### 2-3. VACUUM REQUIREMENTS

a. **Vacuum.** The dictionary definition of a vacuum is a space with nothing at all in it, completely empty space, devoid of all matter, or space containing air or gas at a pressure below that of the atmosphere, or the degree to which pressure has been brought below atmospheric pressure. In the canning industry, the meaning of vacuum is a little different; it is the extent to which air has been eliminated from the can, resulting in a pressure reduction below atmospheric pressure.

b. **Measurement.** Measurement, in the canning industry, is measuring the difference between atmospheric pressure and the existing lower pressure in the closed

container. If atmospheric pressure is normally 14.7 pounds per square inch on the surface of the earth, a decrease in this pressure by 1 pound will create a partial vacuum. Vacuum may be referred to in terms of inches, and the requirements are usually in federal and military specifications. Two inches of vacuum equals a reduction of approximately 1 pound of pressure. Vacuum is commonly measured in inches of mercury.

c. **Purpose.** A condition of partial vacuum is desirable in canned foods for chemical, physical, and biological reasons.

(1) Chemically, it is important to remove the oxygen from air in the headspace of containers. When air is flushed from a container with steam, and the steam condenses, the oxygen content is very low. In addition, a vacuum in a container of food helps protect color and flavor of the product, assists in retaining vitamins, prevents the food product from becoming rancid due to oxidation, and helps retard corrosion of tin plate. (Oxidation causes can corrosion and a rancid condition in food.)

(2) Physically, a vacuum is important in holding the closures on glass jars, keeping the ends concave in cans, and reducing the pressure within containers while they are being treated.

(3) Biologically, a vacuum is of value because it restricts the growth of organisms requiring air for growth (aerobic). This is particularly important for products processed at temperatures below the lethal level of some spoilage microorganisms. However, the lethal process in canning is designed to kill spoilage microorganisms; therefore, the biological importance of a vacuum in a container is of less significance than for the other factors.

## 2-4. MEASURING VACUUM

a. **Vacuum Gauges.** The food industry uses several types of vacuum gauges, most of which puncture the can to determine the vacuum inside. The most commonly used puncture type is the end-puncture gauge (see Figure 2-1), with the side-puncture gauge being used much less frequently. Vacuum may be measured by many different scales--millimeters of mercury, inches of mercury, feet of water, atmospheres, and pounds per square inch. The most common measurement for gauges used by the food industry is inches of mercury.

b. **Metal Rulers.** Tray pack vacuum is measured by using metal rulers of two different sizes. Vacuum gauges are not used with tray packs. The length of a tray pack can be measured by placing a 12 inch metal ruler on the can. The width of a tray pack can is measured by placing a 9 7/8 inch metal ruler on the can. Both ends of the ruler must be in contact with the lid at the inside edge of the double seam. A normal tray pack lid will be slightly concave at the center of the lid where the labeling surface is. If the vacuum is normal, you will be able to see light between the metal ruler and the labeling surface. (See Figure 2-2.)



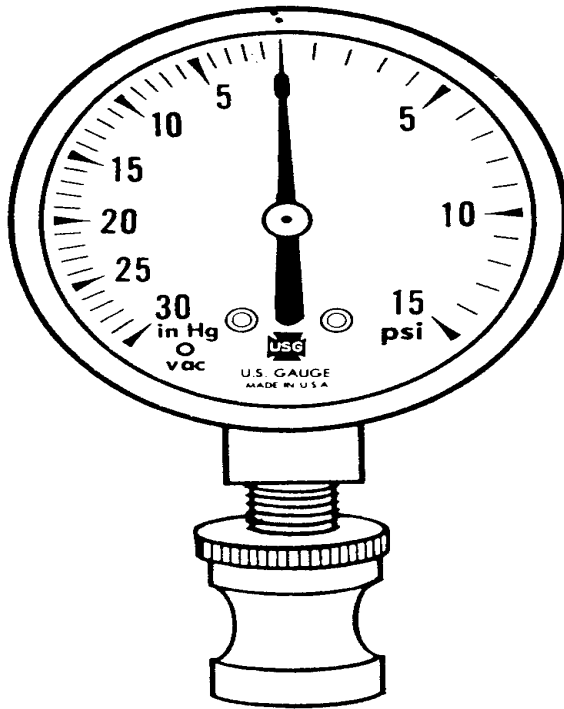

Figure 2-1. Vacuum gauge, end-puncture type.

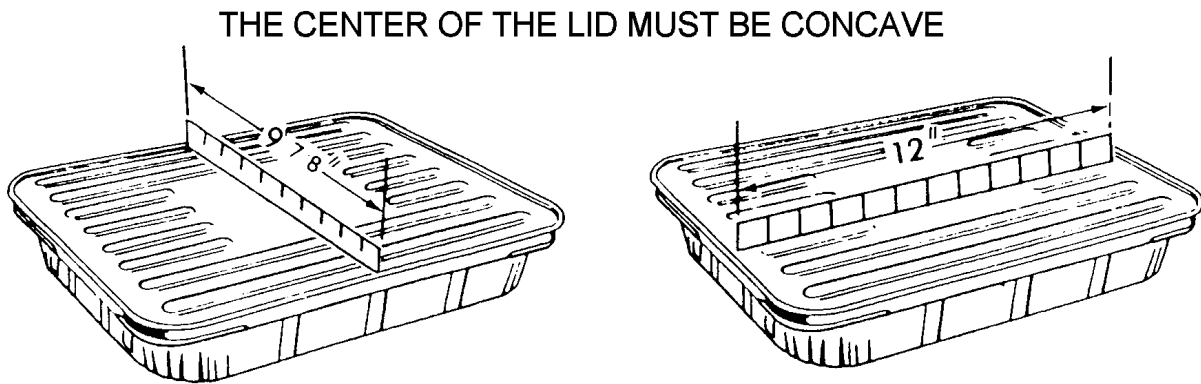

Figure 2-2. Measuring vacuum of a tray pack can.

## **2-5. USING THE VACUUM GAUGE TO DETERMINE VACUUM**

When requirements state a specified vacuum for a canned subsistence item, the end-puncture gauge is normally used (see Figure 2-1). To obtain an accurate vacuum reading, the following steps of procedure must be observed.

### **a. Prepare for Testing Vacuum.**

(1) Assure that dented or defective cans are not used for testing vacuum. For example, never select a swollen can.

(2) Measure vacuum at room temperature, which is normally between 70°F (21°C) and 80°F (27°C).

### **b. Check the Gauge for Serviceability.**

(1) Check for cracks and blockage. Assure that the air entrance is not blocked with foreign material.

(2) Check the rubber gasket to ensure that it is capable of creating a seal. Assure that the gasket is flexible, free of breaks, and has a smooth, clear contact surface. A cracked or damaged rubber gasket will allow air leakage.

(3) Blow into the gauge. The needle should move to the right. The gauge should read "0" when viewed as shown in Figure 2-1.

### **c. Prepare the Can for Puncture.**

(1) Strike the manufacturer's end of the can on a flat surface in order to compact the product.

(2) Place the can on a slanted surface to allow for optimal head-space. The can should be positioned on the slanted surface in such a way that the optimal space is in the area of the side seam and the manufacturer's end of the can.

### **d. Puncture the Can.**

(1) Enter the can as close to the upper edge as possible (see Figure 2-3). Puncture the can on the manufacturer's end as close to the edge of the can as possible, in the area of the side seam, without entering the countersink.

(2) Push the point only far enough to pierce the metal. Pushing too far may allow the gauge to penetrate the product. This will plug the gauge and prevent an accurate reading.

(3) Hold the gauge down to prevent a vacuum leak.

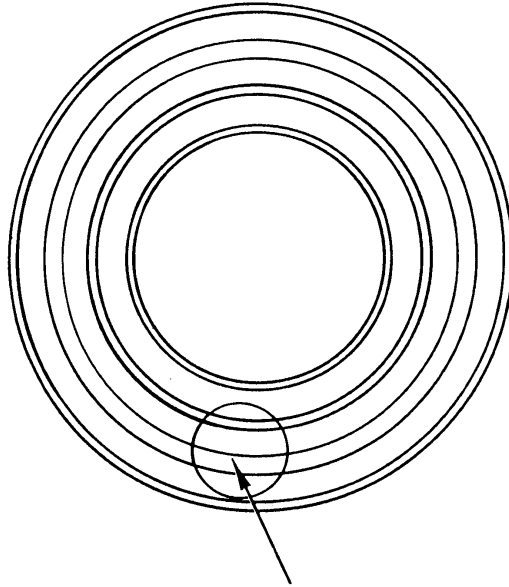

Figure 2-3. Can end, showing where to place the vacuum gauge.

**e. Read the Gauge.**

(1) Tap the gauge lightly. This is to be sure that friction within the gauge will not result in an incorrect reading.

(2) Correct the vacuum reading, compensating for altitude, if applicable. Add 1 inch of mercury for each 1,000 feet above sea level. For example, a reading of 4 inches at an altitude of 2,000 feet may be corrected to 6 inches of vacuum.

**f. Record the Reading.**

(1) Take the reading at the exact moment that the can is pierced.

(2) Take the reading at the maximum point that is reached by the indicating needle.

(3) If the gauge has two scales, as pictured in Figure 2-1, then any movement to the left would indicate vacuum and any movement to the right would indicate pressure. Pressure is an indication of chemical or microbial action taking place within the container.

**g. Clean the Gauge.**

(1) Remove the rubber gasket and wipe with a cloth. Clean the rubber gasket with warm soapy water and rinse.

(2) Wipe the puncture needle with an alcohol-soaked cloth.

(3) Check the air passage. Be sure that any food particles are removed by shaking the gauge with a downward motion.

## **Section II. CONTAINER DEFECTS**

### **2-6. CONTAINER DEFECTS-GENERAL**

a. **Determining Type and Extent of Damage.** The veterinary food inspection specialist must determine whether the packaging materials have been damaged or have deteriorated. Since canned rations play an important part in the feeding programs of the military service, veterinary food inspection specialists must be able to determine whether the item has been properly protected. They must be able to determine the type and extent of damage in order to be able to make proper disposition recommendations of the defective product. The end result of canning procedures is a highly acceptable food product that may be stored for a long period of time.

b. **The Severity of Defects.** In the inspection of canned food items, there are varying degrees of severity of defects. Exterior container defects are classified with regard to the severity of the defect and the effect such a defect may have upon the contents of the can.

c. **Identifying Container Defects.** The ability to identify container defects is the basis for surveillance inspections. Many can defects are associated with the actual manufacturing process and others are caused by handling of the container. In the defense supply system, products must be acceptable after many moves and after long periods of storage. It is part of the duty of the veterinary food inspection specialist to properly identify products that have not withstood these conditions and to remove them from the supply system.

d. **External or Internal Defects.** For the veterinary food inspection specialist's purpose, can defects are usually classed as external defects or internal defects. External defects are those that will be seen during external or closed-package examination, whereas internal defects are those seen during internal or open-package examination.

### **2-7. THE EXAMINATION**

In performing the actual examination of a container, the inspector must use the senses of sight and touch. The inspector should begin by holding the can with end seams resting on the fingertips. Beginning in the side seam vicinity, he should visually examine the can from end seam to end seam and at the same time revolve the can with the fingertips. Revolving the end seams over the fingertips should also detect improper

closures which may not be detected by visual examination. Normal appearing cans should be shaken vigorously to detect leakers (see paragraph 2-12d), and the ends should be struck against a flat surface to detect flippers (see paragraph 2-10b). The containers must be examined under proper illumination in order that visual defects can be easily detected. Examine each container carefully. Refer to inspection aids, as applicable, to properly classify each type of defect.

## 2-8. DEFECT CLASSIFICATION

There are three classifications for container defects.

a. **Critical.** A critical defect may result in hazardous or unsafe conditions for individuals using the product.

b. **Major.** A major defect materially reduces the usability of the unit of product for its intended purpose or has the potential to develop into a critical defect.

c. **Minor.** A minor defect may or may not limit serviceability due to appearance, but it does deviate from the contract and/or specification.

## 2-9. EXTERNAL DEFECTS--DENTS

a. **Dents.** The most prevalent defect discovered during closed-packed inspection is the dent. This is a permanent distortion of the can due to external forces. Dents do not render the product in the container unserviceable or cause the product to present a health hazard. Can dents are judged according to severity and to location and are generally limited to three types: irregularity, moderate dent, and severe dent. Cans containing more than one dent are classified on the basis of the most serious dent. There are no critical defects for dents.

(1) Irregularity. An irregularity is a flaw that does not limit serviceability and is too slight to be considered a minor defect. Irregularities are not listed in the specifications or inspection reports. Irregularities are indentations with small or well-rounded commissures. (A commissure is the place where two bodies or parts unite. It is the junction of the ridges of the dent.) An irregularity has no clearly defined apexes. (An apex is a narrow or pointed end.) An irregularity has no sharp ridges or points present. When an irregularity involves a seam, the malposition can only be detected by measuring.

(2) Moderate dent. A moderate dent is a defect that limits the item's serviceability (including appearance), only slightly or not at all. Nevertheless, this constitutes a deviation from the specification or contract requirements. Moderate dents are classified as minor defects. A moderate dent has moderately deep or sharply rounded commissures and moderately acute apexes. A moderate dent of the end seam will have the seam forced inward but will not involve the countersink and no sharp

ridges will be present. If a body dent involves a seam, it will be considered a moderate dent when malposition of the seam is slight.

(3) Severe dent. A severe dent is a defect that could result in failure or materially reduce the usability of the unit of product for its intended purpose. Severe dents are classified as major defects. A severe dent has very sharp or deep commissures with very sharp apexes. Dents involving a seam are severe when seam malposition is readily noticeable.

**b. End Seam Dent (Figure 2-4).**

(1) Severe. The end seam is forced inward so that the countersink has buckled, the body is extensively involved, or the extremes of the dented part of the flange are reflected at a sharp angle.

(2) Moderate. The end seam is forced inward, but the countersink and body are not involved, and no sharp ridges are evident.

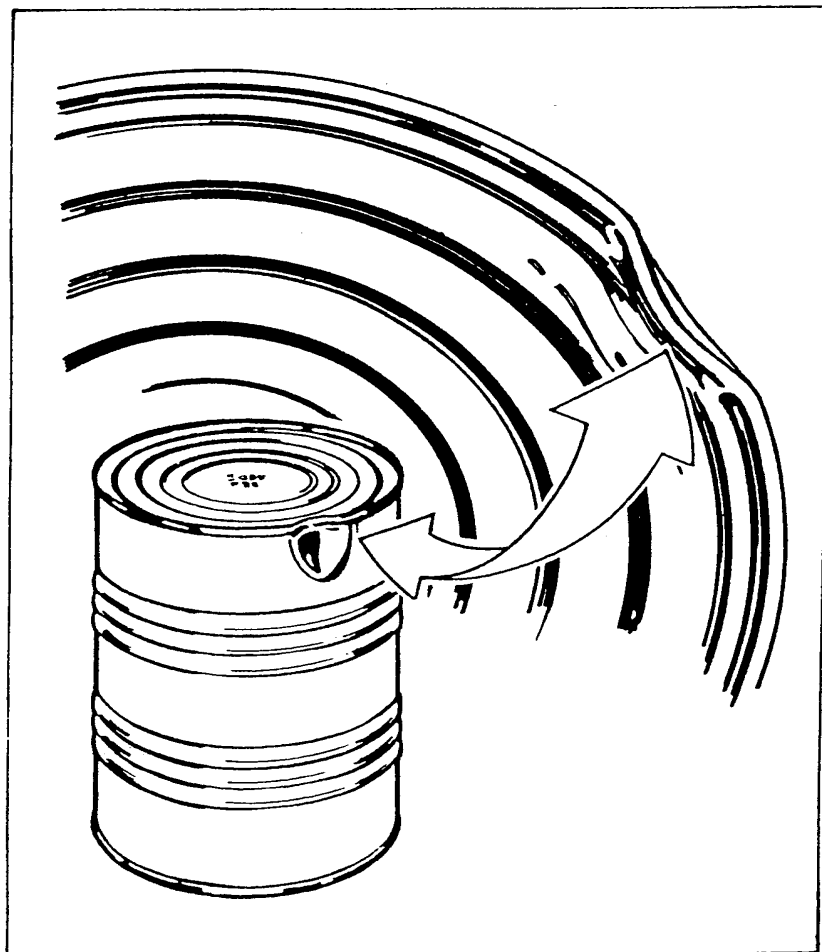

Figure 2-4. End seam dent.

c. **Body Dent Not Involving the End Seam (Figure 2-5).**

(1) Severe. This would be a major defect with very deep or very sharp commissures or very acute angularity of the apex.

(2) Moderate. This would be a minor defect with moderately deep or sharply rounded commissures or moderately acute angularity of apex.

(3) Irregularity. These are small or well-rounded commissures and no clearly defined apex.

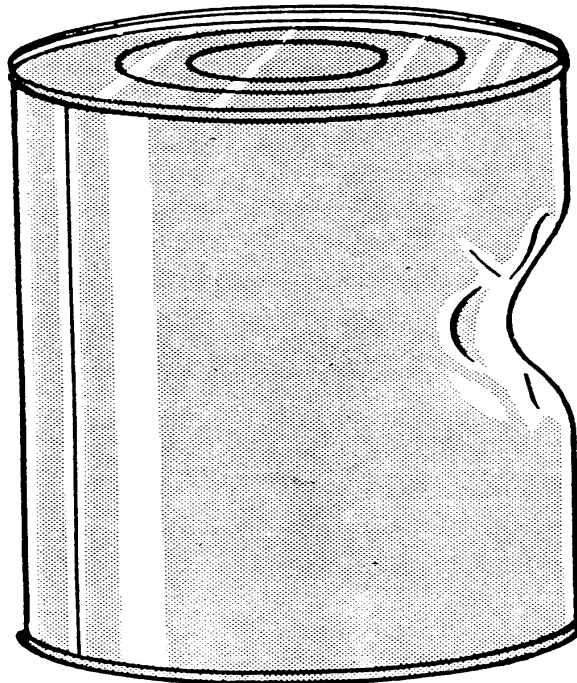

Figure 2-5. Body dent not involving the end seam.

d. **Body Dent Involving End Seam (Figure 2-6).**

(1) Severe. The end seam is pulled out of position to an extent immediately noticeable, and there is some suspicion that the end seam has been under enough tension to break the hermetic seal.

(2) Moderate. The end seam is pulled slightly out of position, but the can must be observed carefully to detect the defect.

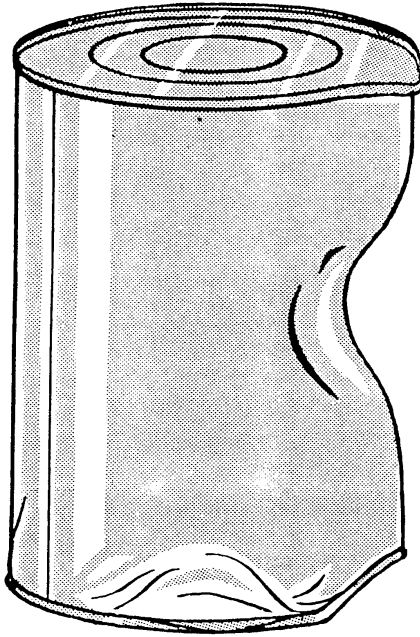

Figure 2-6. Body dent involving the end seam.

## 2-10. EXTERNAL DEFECTS--INTERNAL PRESSURES

External examination of cans will also reveal defects caused by internal pressures being either negative or positive. A negative internal pressure is the result of excessive exhausting or excessive head space following the filling operation and it causes inward movement of the can sides. Positive internal pressure causes an outward distention of the can end. As the pressure increases, the distention becomes more evident. Defect identification is dependent on the amount of the distention present.

a. **Paneling.** Paneling is caused by negative internal pressure, causing one or more flat surfaces on the sides of the can. This is similar to the dent causing a sharp ridge; however, instead of one ridge, there will be two or more, with evidence or suspicion of fracture. It is a result of excessive exhausting or excessive headspace. It is a major defect.

b. **Flipper.** This is a can with little or no vacuum. It appears normal, but when one end is struck on a flat surface, the opposite end will distend and remain distended until forced back into position. It will then stay in that position until the can is struck again. This condition may be the result of overfilling, insufficient exhausting, or chemical or bacterial action. It is a critical defect.

c. **Springer.** A springer has one end distended at all times. Both ends cannot be pushed in at the same time. When the distended end is depressed, the other end



springs outward. This defect is due to microbial or chemical action. It is a critical defect.

d. **Sweller.** This is a can that has both ends distended at the same time. Depending on the amount of internal pressure, the swelling may be subdivided into soft swells, hard swells, and buckled cans. The can ends on a soft swell can be depressed with the thumbs, whereas the ends of a hard swell and buckled cannot be depressed. When this swelling is due to microbial or chemical action, it is a critical defect. Swellers are not critical defects when found in coffee, baking soda, baking powder, or other items that are known to swell and still be fit for human consumption.

e. **Buckled.** A buckled can is a variety of sweller, with so much gas formation (developed during processing) that the countersink is permanently distorted. See Figure 2-7. The buckling in cans may rupture a hermetic seal and relieve the pressure, but the distortion of the countersink remains. A buckled can is also known as a "peaked can." It is a minor defect if the end seam is not involved. It is a major defect if the distortion extends into the end seam. Laboratory testing is required to determine if the reason for the defect is chemical or biological action or a processing defect.

f. **Collapsed Can.** This self-descriptive defect is caused by extreme external pressure during the come-up (pressure increase) period of retorting or by excessive headspace.

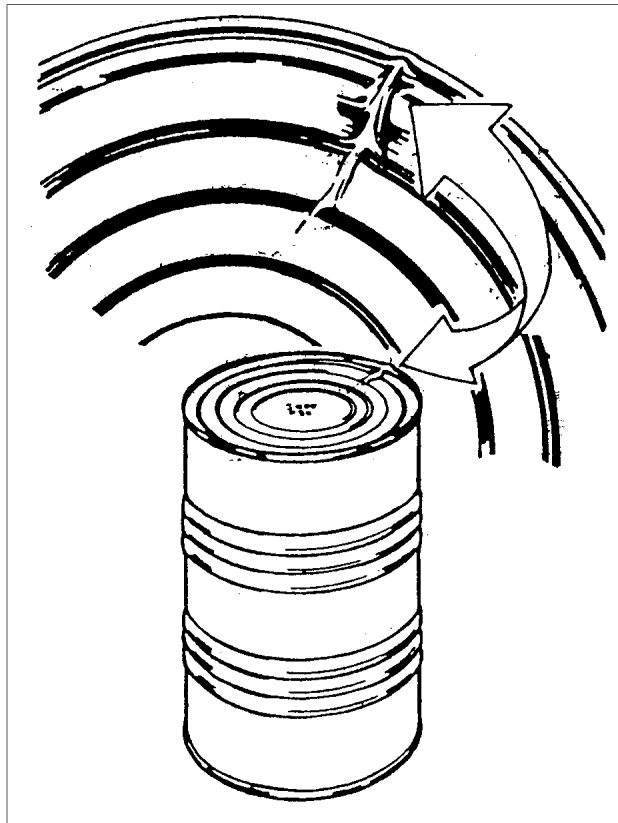

Figure 2-7. Buckling, a buckled can.

## 2-11. EXTERNAL DEFECTS--SEAM DEFECTS

During the manufacturing process of a can, seam defects may occur and result in a false seam or an improper seam. Such seams are hazardous in that a good hermetic seal may not have been formed or the seal may rupture under stress.

a. **Lipper.** A lipper or droop of the end seam is the most common seam defect. It is a major defect. This end seam defect is caused by an incomplete tucking of the cover curl or body flange and the untucked portion will project downward in one of two types, either as a smooth U-shaped droop or a sharp V-shaped projection.

b. **Skipper.** Skippers are caused by the end seam not being completely flattened during the second operational roll. This defect may appear as several droops around the end seam or a slight increase in thickness of the double seam for a short distance. It is a major defect.

c. **Spur.** Similar to a lipper, a spur is an incomplete tuckup of the cover curl in the vicinity of the side seam or at corners of square or rectangular cans. It may be obvious, or it may be indicated only by a slight increase in the width of the double seam for a short distance. It is a major defect.

d. **Spinner.** A spinner (or semiseam) is caused by the can rotating with the rollers during the second operational roll, thereby failing to compress the double end seam and allowing the lid to spin on the can body. A spinner has little or no double seam. It is a critical defect.

e. **Cable Cut.** This end seam defect is the result of cans, usually large cans, remaining stationary on the conveyor line and the abrasive force of the moving line wearing away the metal until the laminations of the double seam are exposed. See Figure 2-8. It is not a defect unless laminations of metal show. It is a major defect.

f. **Open Lap.** This is a defect of the side or body seam. Defects of the side seam are not as prevalent as defects of the end seams, and they all are the result of the can manufacturing process. It is noted by an unsoldered area at the ends of the side seam, immediately adjacent to one of the double end seams. It is a critical defect.

g. **Wormhole.** This is an unsoldered area anywhere along the side seam except in the lap area (double seam area). It is a critical defect.

h. **Cocky Can.** A cocky can is a can that does not have the side seam perpendicular to the end seam. It has an incomplete seam. The side seam is not hooked uniformly for its entire length. It is a critical defect if it is a leaking can. It is a major defect if the can is not leaking.

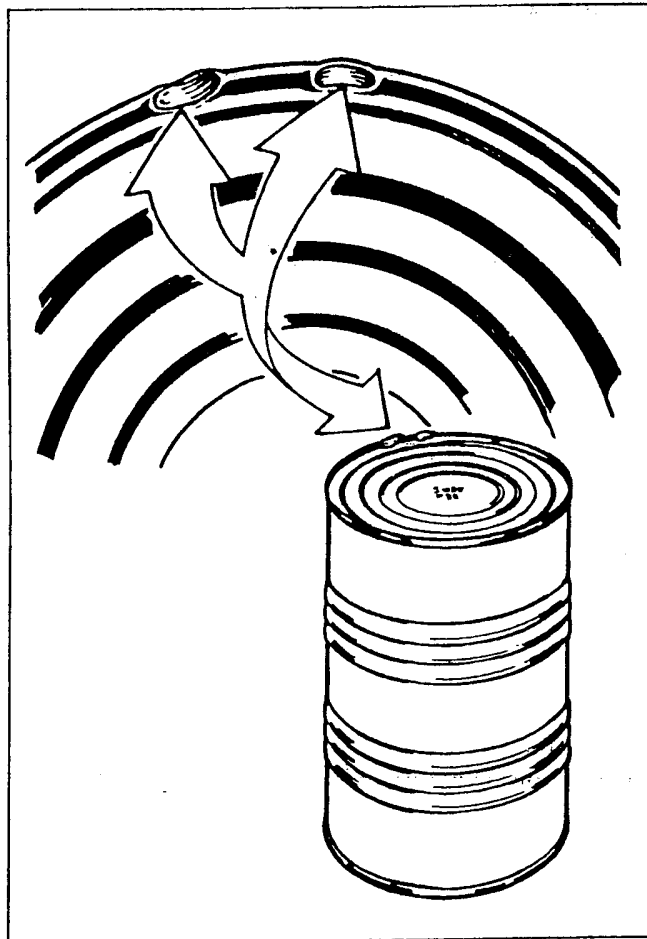

Figure 2-8. Cable cut.

i. **Cracked Seam.** This end seam defect is apparent as a fracture in the double seam (end seam). Foreign material present in the double seam causes the fracture. It is a critical defect.

## 2-12. EXTERNAL CONTAMINATION

During external examination of the can, the veterinary food inspection specialist should note evidence of contamination or deterioration of the container.

a. **Pitted Rust.** A can which has rust, not removable by wiping with a cloth, is called pitted rust. It is a major defect. The rusty areas should be examined closely to be sure the contents of the can are not leaking. When rusty cans start leaking, it is a critical defect.

b. **Dirty Can (Not Clean).** A dirty or unclean can is not clean when there is visible, adhering dirt, filth, grease, or food particles. Cans with a very thin film or grease that is discernible to the touch but not visible to the eye are considered clean.

c. **Excessive Flux.** This is a can with excessive flux on the ends or sides of the can. It is a minor defect. Traces of flux at edges of soldered areas are normal in can manufacturing. It is considered excessive if there is enough to cause corrosion.

d. **Leaker.** A leaker, or leaking can, is a can with a puncture or with rust spots that have perforated the tin or with an incomplete closure of a seam. This defect usually is a progression of other defects and is noted by food contents on the outside of the can, loss of vacuum, absence of the contents of the can, or actually seeing a large perforation. This is a critical defect.

## 2-13. INTERNAL DEFECTS

An internal or open-package examination of containers may reveal defects not seen otherwise or may reveal the cause of defects observed during external examination of the container.

a. **Spangling.** This is a dark discoloration of the interior can body as a result of high acid foods reacting with the tin plate during storage. If the acid is of a certain type, gas will be formed and a sweller will result which is seen during the external examination of the can. Spangling resembles the appearance of a galvanized bucket with the mottling of light and dark colors. The defect may be insignificant or it may be a minor or major defect.

b. **Detinning.** This is much darker than spangling and is normally on one end of the container or covers the whole interior body. The body has reacted with the product to remove the tin plate and has exposed the steel base plate. The defect may be insignificant or it may be a minor or major defect.

c. **Fractured Enamel.** This defect is the result of areas of the tin plate not being covered with enamel. See Figure 2-9. Scarred enamel is the result of imperfect polishing or rolling of the tin plate leaving longitudinal scratches which are not filled with enamel. When enamel chips or flakes off the tin plate, the defect is called flaked enamel. This is the result of a poor baking process or the presence of dirt, water, or grease on the tin plate prior to application of the enamel. The defect may be insignificant or it may be a minor or major defect.

d. **Pinholing.** Pinholing is an internal defect caused by acid product eroding the tin plate. It will be seen either as small pits on the inside of the can or as a leaker if the defect is extensive. It is a critical defect.

e. **Flat Sour.** This defect occurs when the contents of a can have soured or spoiled even though the can has not swollen. It is caused by microorganisms decomposing the product without the formation of gas. It is a critical defect.

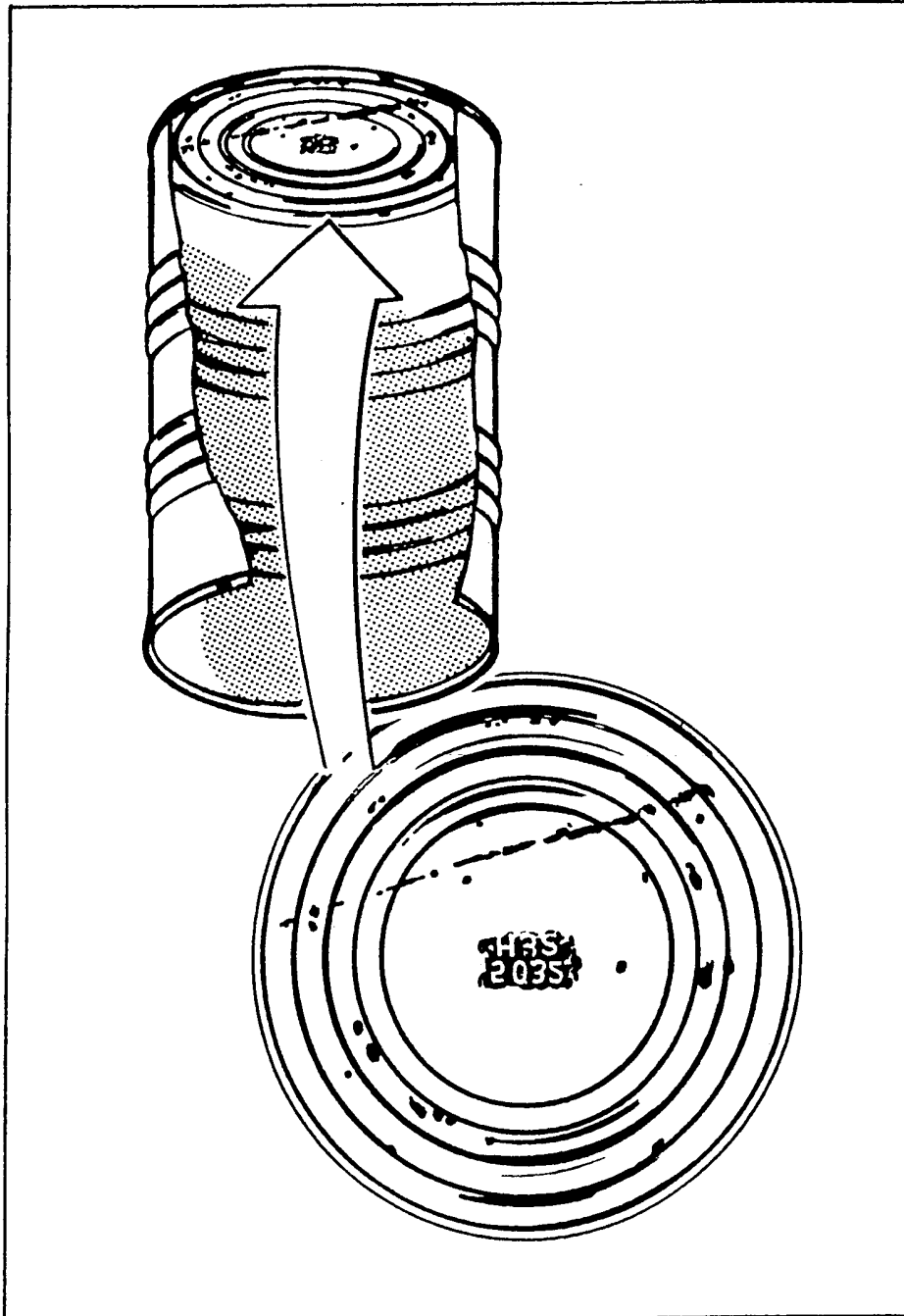

Figure 2-9. Enamel fractures, scarred and flaked enamel.

#### 2-14. GAS-PACKED PRODUCTS

Changes in atmospheric pressure may cause gas-packed products to have distended ends. (Example: Cans containing carbonated beverages often have distended ends.) These cans may or may not be defective. The instructions on the cans, usually advising whom to contact, must be followed.

## 2-15. BREAKAGE - GLASS CONTAINERS

Breakage of glass containers can be divided into three categories, which are based on the cause of the break.

a. **Internal Pressure.** This break has a definite pattern (see Figure 2-10) and is usually midway between the top and bottom of the jar.

b. **Impact.** The container is broken by active impact or by a series of small impacts. There is radial forking. Percussion cones may be formed (see Figure 2-10). Thin-walled containers resist impact breakage best. Those with thick walls are too rigid.

c. **Thermal Shock.** When two portions of a glass container are at widely different temperatures, one expands and the other contracts. Mechanical stress and strain causes a bottle to break from thermal shock (see Figure 2-10).

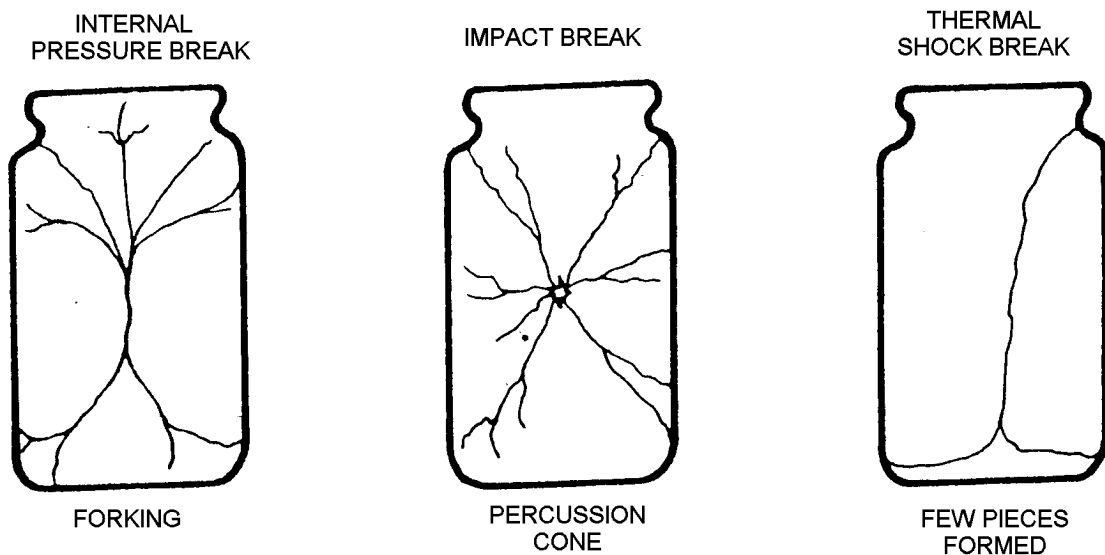

Figure 2-10. Breakage characteristics of glass jars.

## 2-16. SURFACE MARKINGS-BROKEN GLASS CONTAINERS

The surface of a broken glass container has characteristic markings from which information about the break can be obtained (see Figure 2-11).

a. **Origin of Break.** Where the break occurred can be determined by tracing the surface markings backwards.

b. **Ripple Markings.** These marks indicate an area of moderate violence in the movement of the fissure.

c. **Feathering.** This indicates that the fissure forces have slowed.

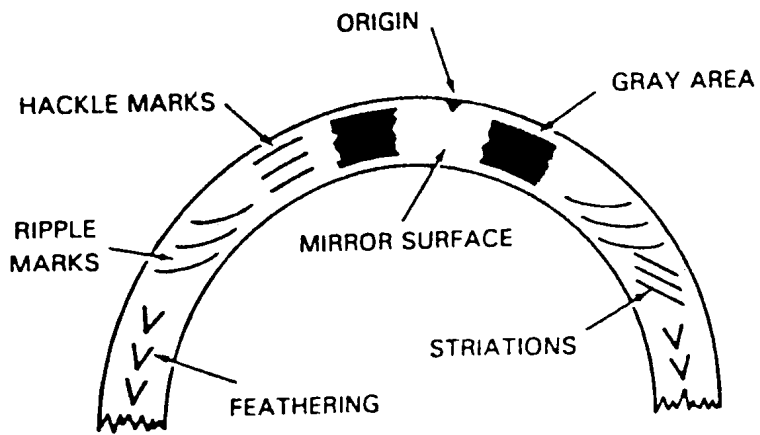

RIPPLE MARKS SHOW DIRECTION OF TRAVEL OF FISSURE

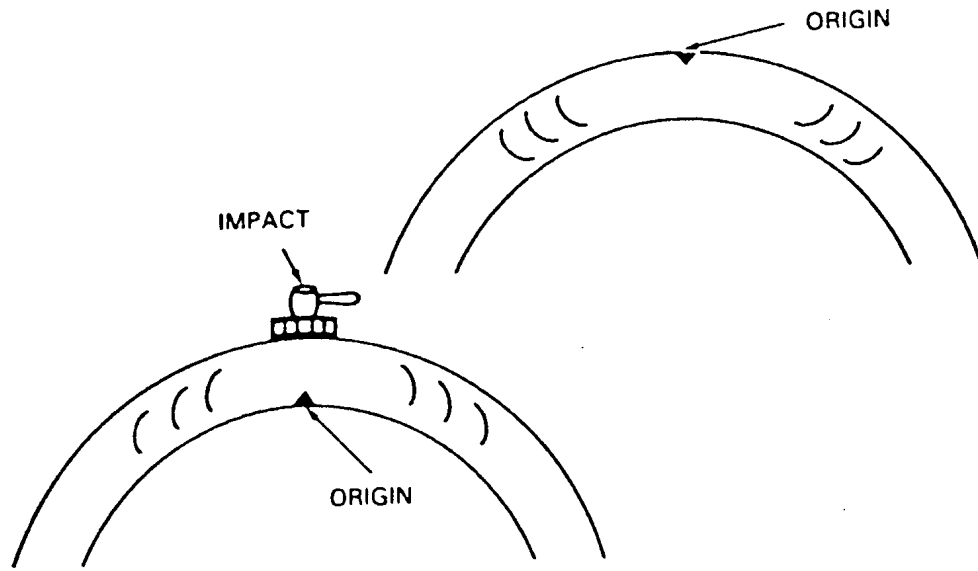

FEATHERS ALSO INDICATE ORIGIN AND DIRECTION

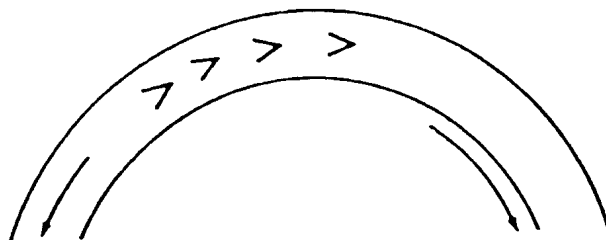

Figure 2-11. Surface markings on broken glass containers.

d. **Gray Area.** A gray area is usually found in pressure breaks. The area of transition between the origin and the appearance of other markings may be mirrorlike, especially if the speed of breaking is at a slow rate at that time. The gray area is the zone of accelerated speed of the break. If the break is uniform, the rough area may not be found.

e. **Percussion Cones.** These marks are characteristics of impact breaks and indicate the point of origin of the impact. If a perfect cone is formed, the break followed the formation of the cone; if there is no cone, the break occurred as the cone was developed.

f. **Featureless Surfaces.** These surfaces are occasionally seen and are characteristic of thermal shock breaks. They indicate that the break occurred slowly and with little violence.

## 2-17. GLASS CONTAINER DEFECTS

A list of common glass container defects follow:

a. **Chip.** A chip is an area where glass has been broken off, but the bottom or body wall is not materially weakened. It is a minor defect.

b. **Stone in Glass.** This defect has the appearance of a lump in the glass. It is an unmelted opaque material imbedded in the glass. It is a minor defect.

c. **Pitted Area.** This refers to small indentations or pits which are apparent on the surface of the glass. A pitted area affects the appearance of a glass container but not the usability of the container. It is a minor defect.

d. **Sagging Surface.** This refers to a wavelike distortion on the surface of the body wall. It is a minor defect.

e. **Thin Spot.** A thin spot is an area where the body wall is decidedly thinner and weaker. It is a major defect. This defect refers to corrosion underneath the cap. It is a major defect.

f. **Check.** A check is a checked crack. This defect is a slight, feathered crack that does not leak; however, it weakens the body wall. It is a major defect.

g. **Pitted Rust.** This defect refers to corrosion underneath the cap. It is a major defect.

h. **Bead.** A bead is a bubble in the body wall which exceeds 1/8 inch in diameter. This defect weakens the body wall. It is a major defect.



i. **Blister.** A blister is an elongated bubble that weakens the body wall. It is a major defect.

j. **Bird Swing.** This defect is a thread-like glass appendage inside the glass container. It is a critical defect.

k. **Leaker.** A leaker has product leaking out of the container. It is a critical defect.

## 2-18. RETORT POUCH DEFECTS

In general, retort pouch defects are similar to can defects. However, the differences require some difference in explanation. Many new names appear in the list of defects.

a. **Leaker.** A leaker's pouch with an incomplete closure of a seal or a puncture that has ruptured the hermetic seal. This is likely to cause a hazardous or unsafe condition for individuals using the product.

b. **Sweller.** Swellers may result from chemical changes or microbial growth which produce gas. This is a hazardous or unsafe condition. Most retort pouch products exhibit a slight vacuum indicated by a mild adherence of the pouch material to its contents. However, the retorted cakes which are found in the MRE often exhibit no vacuum or a slight swelling. These should not be construed as defects unless an open-package inspection or laboratory analysis reveals deterioration.

c. **Tear, Cut, or Hole.** Any tear, cut, or hole in the pouch is likely to cause a hazardous or unsafe conditions for individuals using the product. Such defects are usually due to mechanical damage or the way the container is handled.

d. **Nonfusion Bonded Seal.** A fusion bonded seal is one in which the inner layer of the two sides of the pouch are melted into one mass, producing a hermetic seal. The two separate layers can no longer be identified. If the seal can be pulled apart, the bond is nonfusion.

e. **Inadequate Seal.** An adequate closure seal is any uncontaminated, fusion bonded, continuous path from side seal to side seal that produces a hermetically sealed package. A minimum width is normally specified for this continuous path. Current military specifications require a minimum of 1/16 inch.

(1) Entrapped matter. Food, water droplets, or foreign matter may be trapped during sealing, which prevents fusion bonding of a portion of the seal. The entrapped matter may produce a leaker or a seal width less than the minimum specified.

(2) Fold-over wrinkle. This defect occurs during sealing when one side of the laminate folds on itself, thus reducing the integrity of the seal. It is likely to cause a hazardous or unsafe condition.

(3) Bloater. Entrapped air in a menu bag is not a defect if the pouch is not bulging. If there is bulging, it is an early sign of possible deterioration and may restrict the use of the product.

(4) Loss of vacuum. This refers to flexible containers. The loss of vacuum is evident because the container does not cling tightly to the product. This makes the product less useful than it should be and is an early sign of deterioration.

**f. Breakdown of Pouch Material.**

(1) Delamination. Delamination is the separation of the laminate layers. This defect is most often noticed as a separation of the outer (polyester) layers from the middle (aluminum foil) layer.

(2) Brittleness. Brittleness is a reduction in the flexibility and strength of the laminate and may result from the stresses of time and temperature. Brittleness may lead to tears, cuts, or holes in pouches.

***Continue with Exercises***

## EXERCISES, LESSON 2

**REQUIREMENT.** The following exercises are to be answered by marking the lettered response that best answers the question or by completing the incomplete statement or by writing the answer in the space provided at the end of the question.

After you have completed all the exercises, turn to "Solutions to Exercises" at the end of the lesson and check your answers.

1. The \_\_\_\_ incubates representative sample cans from each retort for \_\_\_\_ days at \_\_\_\_° to \_\_\_\_° Fahrenheit to test the adequacy of commercial sterilization.
  
2. In the canning industry, vacuum is the extent to which \_\_\_\_ has been eliminated from the can.
  
3. Vacuum is commonly measured in inches of \_\_\_\_\_.
  
4. Vacuum in a food container helps protect the \_\_\_\_\_ and \_\_\_\_\_ of the product, assists in retaining \_\_\_\_\_, prevents the food product from becoming \_\_\_\_\_ due to oxidation, and helps retard \_\_\_\_\_ of tin plate.
  
5. What instrument is used to obtain an accurate vacuum reading from the inside of a can?
  
6. List the steps of procedure in using the vacuum gauge to determine vacuum.
  - a. \_\_\_\_\_.
  - b. \_\_\_\_\_.
  - c. \_\_\_\_\_.
  - d. \_\_\_\_\_.
  - e. \_\_\_\_\_.
  - f. \_\_\_\_\_.
  - g. \_\_\_\_\_.

7. The optimal temperature range at which the veterinary food inspection specialist tests sample cans for vacuum is:

- a. 60°F to 70°F.
- b. 65°F to 75°F.
- c. 70°F to 80°F.
- d. 75°F to 85°F.

8. Where on the sample can should the veterinary food inspection specialist make his puncture with the vacuum gauge when he tests for vacuum?

- a. Center of the can end.
- b. Between the body side and the can end.
- c. Anywhere on the can away from a distortion.
- d. In the area of the side seam.

9. To examine a can, you should begin by holding the can with the end seams resting on the fingertips.

- a. True.
- b. False.

10. When examining a can, should you observe the side seam from end to end and then revolve the can one complete rotation while visually examining the can sides?

- a. Yes.
- b. No.

11. When examining a can, you should shake the can vigorously and strike the ends against a flat surface.

- a. True.
- b. False.

12. Which of the following constitutes a minor defect in examination of cans for external defects?
- a. A defective seam.
  - b. An irregularity in the can's exterior.
  - c. A moderate dent in the can's body.
  - d. A severe dent in the body of the can.
13. A can with incomplete closure of a seam, a puncture, or rust spots that have perforated the tin is termed a \_\_\_\_\_.
14. A can that has both ends distended at the same time is a \_\_\_\_\_.
15. Rust that cannot be removed from the can by wiping with a soft cloth is termed \_\_\_\_\_ rust.
16. A can with only one end distended at all times is termed a \_\_\_\_\_.
17. An incomplete tuckup of the cover curl in the vicinity of the side seam is a \_\_\_\_\_.
18. When a portion of the double seam is not flattened in several places by the second operational roll, the can is called a \_\_\_\_\_.
19. Dark discoloration of the interior can body resembling a galvanized bucket is \_\_\_\_\_.
20. A can with adhering dirt, filth, grease, or food particles is a \_\_\_\_\_.
21. An abrasion of the double seam caused by the action of cable conveyors on stationary cans is termed a \_\_\_\_\_.

22. A body dent with small or well-rounded commissures and no clearly defined apex is a(n) \_\_\_\_\_.

23. The three categories of breakage of glass containers are:

a. \_\_\_\_\_.

b. \_\_\_\_\_.

c. \_\_\_\_\_.

24. Which marks on the surface of a broken glass container indicate an area of moderate violence in the movement of the fissure?

a. Feathering.

b. Gray area.

c. Ripple markings.

d. Origin of break.

e. Featureless surfaces.

25. Which marks on the surface of a broken glass container are characteristic of impact breaks?

a. Feathering.

b. Featureless surfaces.

c. Ripple markings.

d. Gray area.

e. Percussion cones.

26. During the examination of a retort pouch, a leaker is found. What is a leaker?

A leaker is a pouch with an \_\_\_\_\_ or a \_\_\_\_\_ that has ruptured the \_\_\_\_\_.

27. During the examination of a retort pouch, you find delamination. What is delamination?

Delamination is the \_\_\_\_\_ .

28. During the examination of a retort pouch, if the hermetic seal of two separate layers can be pulled apart, what is the defect?

- a. Sweller.
- b. Nonfusion bonded seal.
- c. Inadequate seal.
- d. Breakdown of pouch material.

29. List six common glass container defects.

Minor defect (1)

(2)

(3)

(4)

Major defect (1)

(2)

(3)

(4)

(5)

Critical defect (1)

(2)

30. As you inspect a retort pouch, you notice that the container does not cling tightly to the product. This defect is known as:

- a. Delamination.
- b. A bloater.
- c. A sweller.
- d. Loss of vacuum.

***Check Your Answers on Next Page***



## SOLUTIONS TO EXERCISES, LESSON 2

1. USDA...10...90...100 (para 2-2)
2. air (para 2-3a)
3. mercury. (para 2-3b)
4. color...flavor...vitamins...rancid...corrosion (para 2-3c(1))
5. The end-puncture vacuum gauge. (para 2-4a)
6.
  - a. Prepare for testing the vacuum.
  - b. Check the gauge for serviceability.
  - c. Prepare the can for puncture.
  - d. Puncture the can.
  - e. Read the gauge.
  - f. Record the reading.
  - g. Clean the gauge. (para 2-5)
7. c (para 2-5a(2))
8. d (para 2-5d(1))
9. a (para 2-7)
10. a (para 2-7)
11. a (para 2-7)
12. c (para 2-9a(2))
13. Leaker. (para 2-12d)
14. Sweller. (para 2-10d)
15. Pitted. (para 2-12a)
16. Springer. (para 2-10c)
17. Spur. (para 2-11c)
18. Skipper. (para 2-11b)
19. Spangling. (para 2-13a)

- 20. Dirty can. (para 2-12b)
- 21. Cable cut. (para 2-11e)
- 22. Irregularity. (para 2-9c(3))
- 23.
  - a. Internal pressure.
  - b. Impact.
  - c. Thermal shock. (para 2-15)
- 24. c (para 2-16b)
- 25. e (para 2-16e)
- 26. incomplete closure of a seal...puncture...hermetic seal. (para 2-18a)
- 27. separation of the laminate layers. (para 2-18f(1))
- 28. b (para 2-18d)
- 29.
 

Minor defect	<ul style="list-style-type: none"> <li>(1) Chip.</li> <li>(2) Stone in glass.</li> <li>(3) Pitted area.</li> <li>(4) Sagging surface.</li> </ul>
Major defect	<ul style="list-style-type: none"> <li>(1) Thin spot.</li> <li>(2) Check.</li> <li>(3) Pitted rust.</li> <li>(4) Bead.</li> <li>(5) Blister.</li> </ul>
Critical defect	<ul style="list-style-type: none"> <li>(1) Birdswing</li> <li>(2) Leaker. (para 2-17)</li> </ul>
- 30. d (para 2-18e(4))

***End of Lesson 2***

# COMMENT SHEET

**SUBCOURSE MD0708 Food Containers**

**EDITION 100**

Your comments about this subcourse are valuable and aid the writers in refining the subcourse and making it more usable. Please enter your comments in the space provided. ENCLOSE THIS FORM (OR A COPY) WITH YOUR ANSWER SHEET **ONLY** IF YOU HAVE COMMENTS ABOUT THIS SUBCOURSE..

**FOR A WRITTEN REPLY, WRITE A SEPARATE LETTER AND INCLUDE SOCIAL SECURITY NUMBER, RETURN ADDRESS (and e-mail address, if possible), SUBCOURSE NUMBER AND EDITION, AND PARAGRAPH/EXERCISE/EXAMINATION ITEM NUMBER.**

## PLEASE COMPLETE THE FOLLOWING ITEMS:

(Use the reverse side of this sheet, if necessary.)

1. List any terms that were not defined properly.

---

---

---

---

2. List any errors.

paragraph      error      correction

---

---

---

---

---

---

---

---

3. List any suggestions you have to improve this subcourse.

---

---

---

---

4. Student Information (optional)

Name/Rank \_\_\_\_\_

SSN \_\_\_\_\_

Address \_\_\_\_\_

E-mail Address \_\_\_\_\_

Telephone number (DSN) \_\_\_\_\_

MOS/AOC \_\_\_\_\_

### PRIVACY ACT STATEMENT (AUTHORITY: 10USC3012(B) AND (G))

**PURPOSE:** To provide Army Correspondence Course Program students a means to submit inquiries and comments.

**USES:** To locate and make necessary change to student records.

**DISCLOSURE: VOLUNTARY.** Failure to submit SSN will prevent subcourse authors at service school from accessing student records and responding to inquiries requiring such follow-ups.